

Z90-Control by K8ZOA

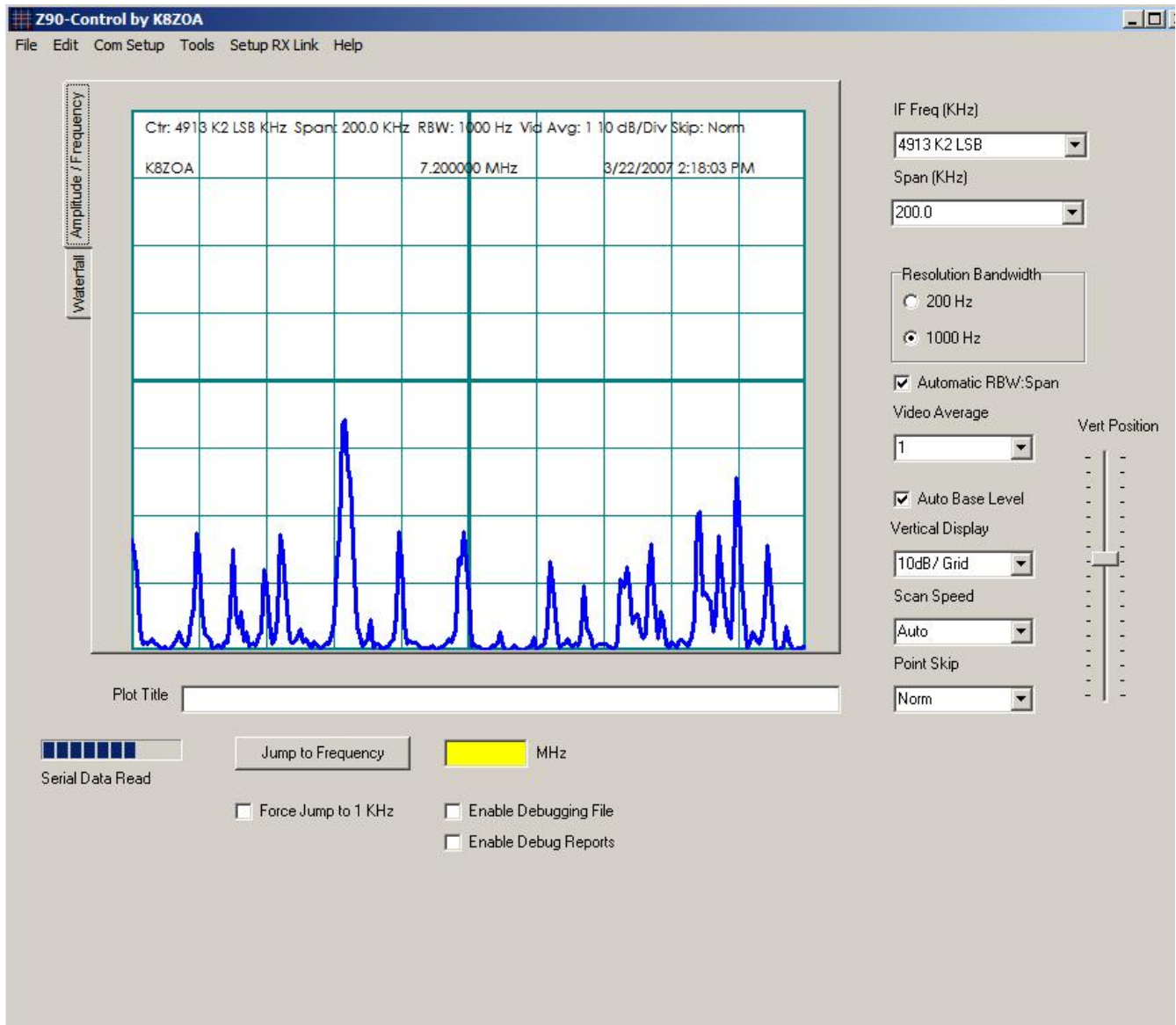

VertBar TrackBar
 SkipCombo ComboBox
 ScanSpeedCombo ComboBox
 TitleEdit Edit
 Video Averaging
 Vertical Display
 Jump to Frequency
 Enter Frequency
 Force Jump to 1 KHz
 Enable Debugging File CheckBox
 Enable Debug Reports
 Auto Base Level
 Automatic RBW:Span CheckBox
 IF Selection
 Serial Data Read Progress

First Time Running

The first time you run ExpSerial you will need to select the communications ports connected to your Z90/Z91 and, optionally, to your K2

transceiver's serial port. Both ports are selected from the main menu, COM SETUP | SELECT Z90 PORT for the Z90 and SETUP RX LINK for the K2. Select the appropriate ports via the drop down lists and select OK.

Select Comm Port
Setup Receiver Link

Enable Debugging File

Enable Debugging File

As an aid in reporting problems with Z90 Control software to Clifton Laboratories, the program includes an option to capture many internal operations and values to a text file, titled expdump.txt. This file is written in the same directory as is the Z90.INI file.

Because this file rapidly becomes large, this option should be enabled only where necessary to aid in debugging. When disabled, the file will still be created, but its contents will be empty.

Note: This option is only displayed if the menu item Help | Show Debug Options is enabled.

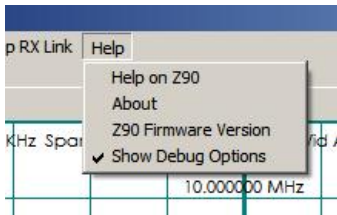

Enable Debug Reports

Enable Debug Reports

As an aid in reporting problems with Z90 Control software to Clifton Laboratories, the program includes an option to capture many internal operations and values and display them to a memo text box.

To improve program speed and memory usage, this option should be enabled only where necessary to aid in debugging.

Typical output when enabled

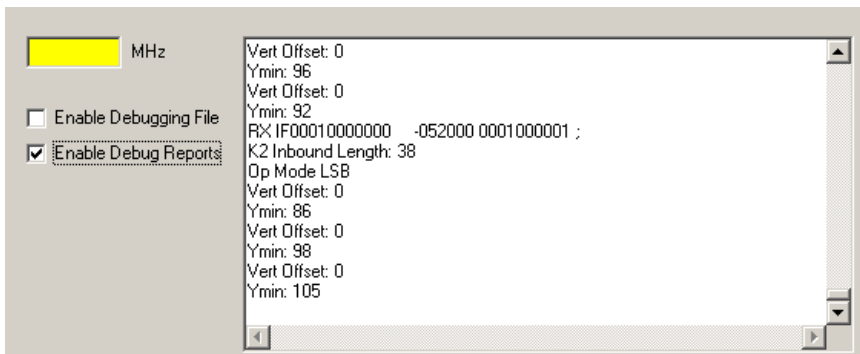

Note: This option is only displayed if the menu item Help | Show Debug Options is enabled.

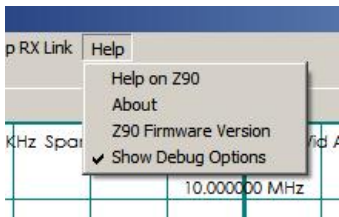

Changes in Version 2.0

Z90 Control version 2.0 implements a number of useful new features, including:

- Windows Vista compatibility. Z90 Control version 2 is compatible with Microsoft's Windows 2000, Windows XP and Windows Vista operating systems.
- Faster screen redraws. Version 2.0 has been rewritten from scratch in Borland Turbo Delphi version 2006.
- New waterfall display mode; provides a 350 line history of previous data sweeps.
- Amplitude versus frequency mode can be displayed in either line (oscilloscope) mode or bar graph mode
- User-editable features include line color, line thickness, font selection and background color.
- Elecraft K2 integration, including frequency readout and "jump to" frequency mode allowing you to click the mouse on either display mode and see the actual RF frequency. Then, clicking on a button will automatically tune your K2 to that frequency.
- Context sensitive help, with individual help screens, keyed to the active control.

Visit [Clifton Laboratories home page](#) to keep up to date on our activities.

You may also [contact Clifton Laboratories by E-mail](#).

Automatic RBW:Span Link and RBW Selection

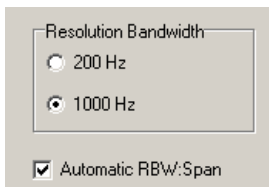

The Z90 has two resolution bandwidths (RBW); 200 Hz and 1 KHz. The RBW may be selected in two fashions:

1. Manually, by selecting 200 Hz or 1 KHz via the radio buttons.
2. Automatically, where the Z90 selects the most appropriate RBW based upon the span.

Selecting the Automatic box allows the Z90 to make the RBW selection based on the current span. Changing the span may change the RBW, which will be reflected in changes in the selection displayed. If the Automatic function is enabled and you make a manual RBW selection, the next time you change Span, the Z90 will recompute the most appropriate RBW and may alter your selection. If you wish to override the Z90 and keep the span at your manual selection regardless of your span selection, uncheck the Automatic RBW:Span checkbox.

In selecting RBW, remember that the Z90 will capture a maximum of 240 data points. If the span is set at 100 KHz, for example, and the RBW at 200 Hz, the resulting data display will almost certainly be in error.

RBW is also related to sweep speed; the narrower the RBW, the more time required for a sweep. This is a consequence of the rise time of a narrower filter being greater than a wider filter. Hence, the Z90's firmware selects a sweep speed suitable for the RBW, unless manually overridden via the Scan Speed function.

IF Selection



The drop down list selects from amongst the possible IF frequencies, including the three user-defined custom IF frequencies.

Custom IF frequencies may be set via the TOOLS | DEFINE CUSTOM IF menu.

If you implement Elecraft K2 mode integration, you must define the three Custom IF frequencies in a specific fashion.

Beginning with version 2.0, you may also add optional alphanumeric tags to the Custom IF frequencies.

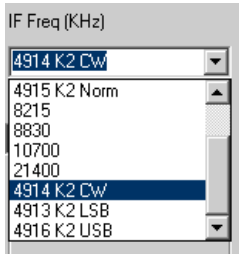

To add alphanumeric tags use the following procedure:

Locate the Z90-Control program's initialization file, Z90.INI. This should be in the directory described during the installation process, c:\documents and settings\\Application data\CliftonLabs\. If you cannot find it, use Windows's Search function (START | SEARCH) and search for the file name Z90.INI. Open the file with Notepad or similar text editing program and you should see the following contents (other parts are not shown):

```
[IFTags]
Tag0=
Tag1=
Tag2=
Tag3=
Tag4=
Tag5=
Tag6=
Tag7=
Tag8=
Tag9=
Tag10=
```

After each TagN= line, you may enter a brief text note that will appear after the IF frequency in the drop down box.

Serial Data Read Progress

The Serial Data Read progress bar shows incoming serial data from the Z90/Z91. Its purpose is to provide a visual indication that data is being received over the serial port. If your Z90 is connected and the progress bar does not show inbound data, check the following possible error sources:

1. Is the data cable connected at both ends?
2. Is the correct data cable used? The cable should be a "straight through" cable where pin 2 at one end connect with pin 2 at the other end, etc.
3. Have you correctly selected the Z90 serial port using the COM SETUP menu?
4. Have you tried manually starting data flow using the COM SETUP menu?

If all of these steps fail, please verify that you have connectivity with the Z90 using the steps identified in the assembly manual employing a communications program, such as Terminal.

Auto Base Level

Auto Base Level

Auto Base Level functions with normal trace (either line or bar) mode and adjusts the base line for each sweep so that the minimum signal level value corresponds to the bottom graticule line. Auto Base Level prevents or reduces "base line lifting" due to strong out-of-band signals being detected by the AD8307 log amplifier due to filter blow by. Auto Base Line only works on the Z90 Control program and does not change the vertical position of the Z90's LCD display. For optimum viewing experience, Auto Base Level should be enabled.

Point Skip Factor

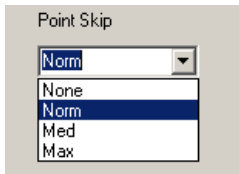

Determines how the Z90 collects and displays data by adjusting the number of frequency steps for each scan. The Z90 uses a discrete step design, rather than a continuously variable sweep as employed with analog spectrum analyzers. One data point (vertical axis value) is taken for each frequency step.

The graticule area of the LCD screen (upon which the data output format is based) is 240 pixels wide. In the maximum resolution mode, a separate frequency step and amplitude measurement is made for each pixel. Depending upon the span and bandwidth, this can be unnecessary. For example, if the span is 10 KHz, each pixel corresponds to a frequency increment of 41.7 Hz. Even with the narrowest resolution bandwidth of 200 Hz, it takes nearly 5 horizontal steps for the filter's 3 dB bandwidth to be crossed. Hence, by taking measurements every second or every third frequency step, it is possible to increase scan speed and the refresh interval significantly, without introducing unacceptable amplitude error. This process is called "point skipping" in the Z90.

Since the exact number of points that are appropriate to skip is a function of the resolution bandwidth and the span, the Z90 firmware automatically computes an appropriate skip interval, based upon the user's entry of the optional skip command. The skip commands are:

- None-240 data points are always taken
- Norm-Fewer data points are taken, but always at least 120 points
- Med-At least 80 points are taken
- Max-At least 40 points are taken

For most purposes operating with "Norm" will provide a good balance between sweep speed, accuracy and display smoothness.

Since the Z90 computes the actual skip interval, don't be surprised to see 240 data points taken even though you have selected "max" option. For example, if you have selected 200 KHz span, and 1 KHz bandwidth, the Z90 firmware will collect 240 data points--regardless of the Point Skip setting--as any fewer points permit major errors in amplitude measurement.

The effect of differing point skip is shown in the following four figures. As the skip factor increases, the trace progressively shows less detail.

Skip-None. Always takes 240 data points

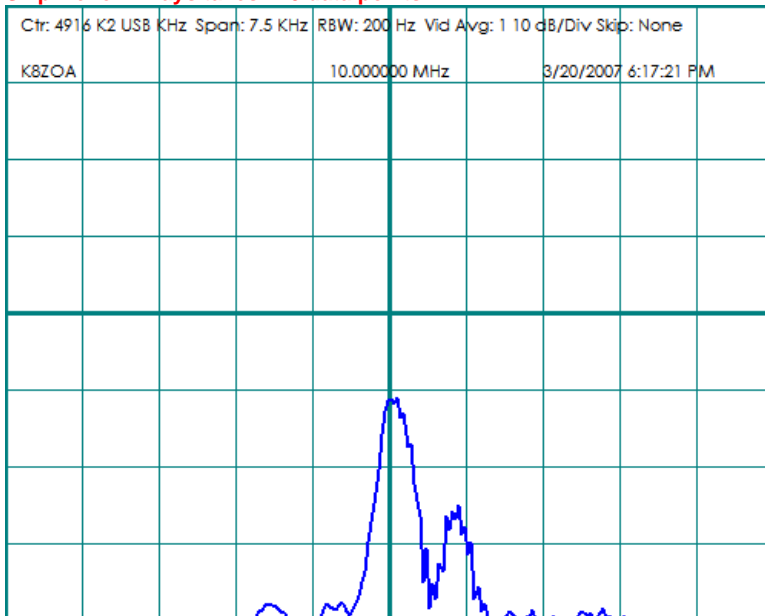

Skip-Norm

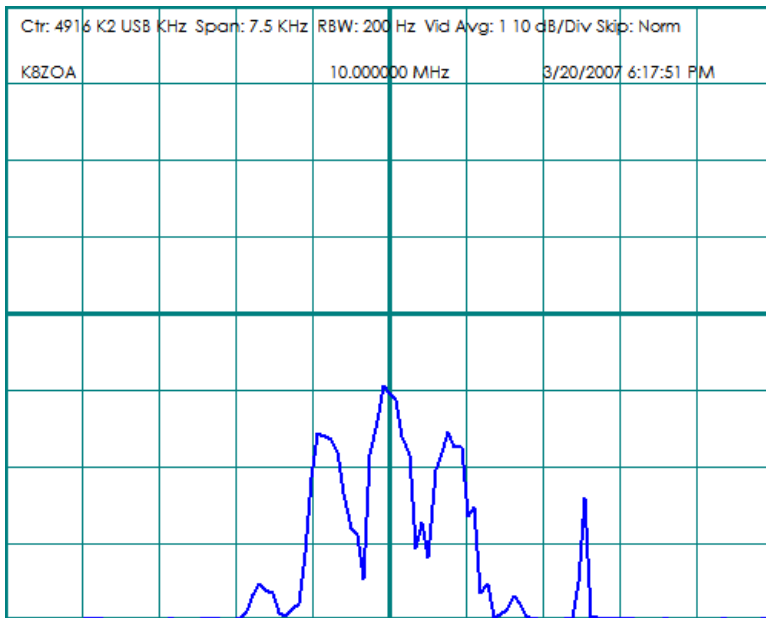

Skip Med

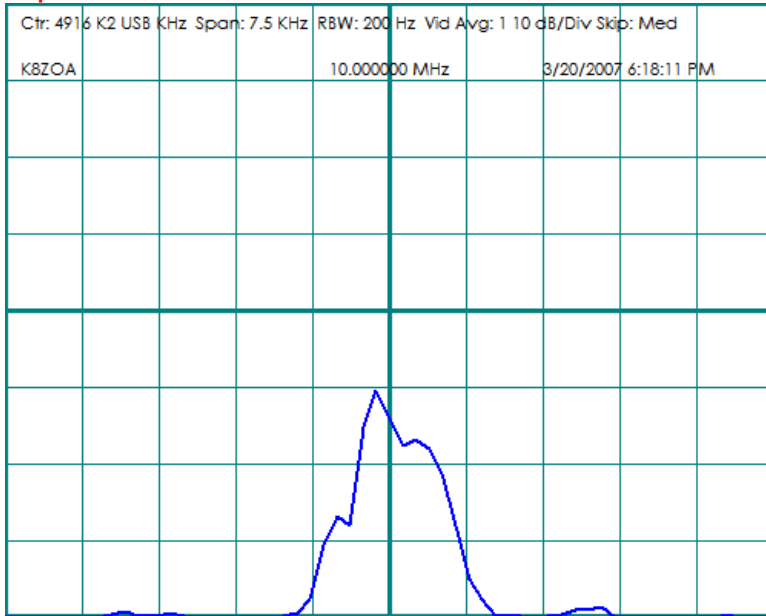

Skip Max

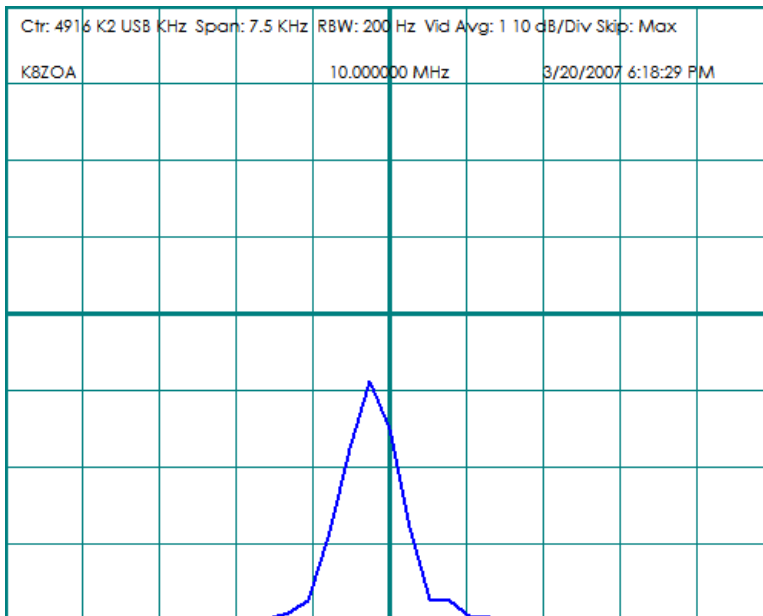

Scan Speed

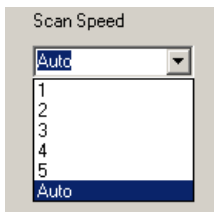

The Scan Speed adjustment determines how long the Z90 waits to measure amplitude after shifting frequency to a new scan point. The possible options are:

1...5, corresponding to 1...5-milliseconds delay

AUTO-the optimum delay is computed automatically by the Z90 firmware.

The irreducible delay, due to software computation loads in the Z90 firmware is roughly 1.5 ms so the observable difference between 1 and 2 ms dwell will be minimal.

The interaction between dwell time and amplitude error is most seen when the 200 Hz filter is used. In order to accurately reproduce the amplitude data, the dwell time should be approximately $1/\text{filter bandwidth}$, or 5 ms for the 200 Hz filter and 1 ms for the 1 KHz filter. These are the values used by the Z90 firmware when in AUTO mode.

In most circumstances, selecting AUTO is the correct choice. In some cases, it may be desirable to select additional delay when using the 1 KHz filter, particularly if using aggressive point skip factors. This is because a frequency step may correspond to a large change in filter amplitude when on the filter flank, and the additional settling time permits a better amplitude measurement.

Vertical Position



Use this slider control to adjust the vertical position. The control always sends a command to the attached Z90, but will alter the computer screen trace position only if Auto Baseline is disabled.

Title

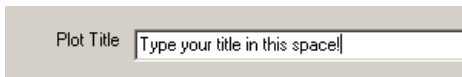

If you wish to add a title to the plot (amplitude versus time or waterfall) type the text here.

The title will appear at the top of the plot

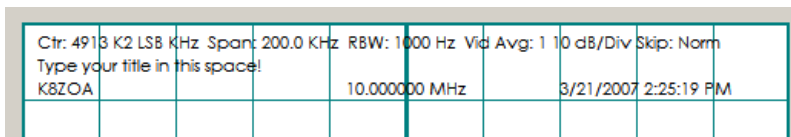

Video Averaging

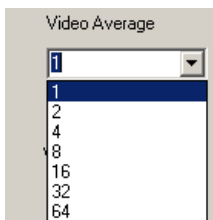

The Video Averaging function determines how many readings are averaged to determine the signal amplitude. Possible values are 1, 2, 4, 8, 16, 32 and 64. Increasing the video averaging factor reduces noise, but slows the overall scan rate and increases errors on signals with rapidly changing values.

Video averaging performs a function similar to Video Bandwidth Selection in a spectrum analyzer, in that the more samples averaged, the lower the video bandwidth.

Vertical Display

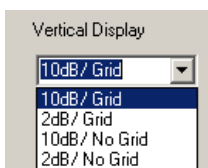

The Vertical Display function selects four possible values of vertical gain and graticule display:

- 10 dB/div and graticule
- 2 dB/div and graticule
- 10 dB/div without graticule
- 2 dB/div without graticule

Note that when operating in 2 dB/Div mode, careful adjustment of the vertical position will be necessary and the automatic baseline function should be disabled. In the following example, vertical position in 2 dB/Div mode was about half-way. It is normal for the signals to appear as narrow spikes, as the total vertical range is only 16 dB.

Signals in 10 dB/Div mode

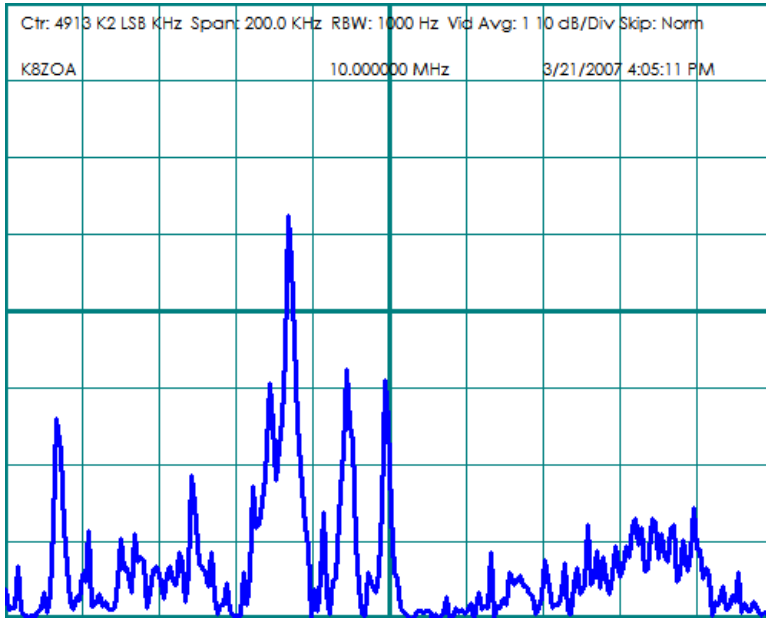

Same signals but in 2 dB/Div mode

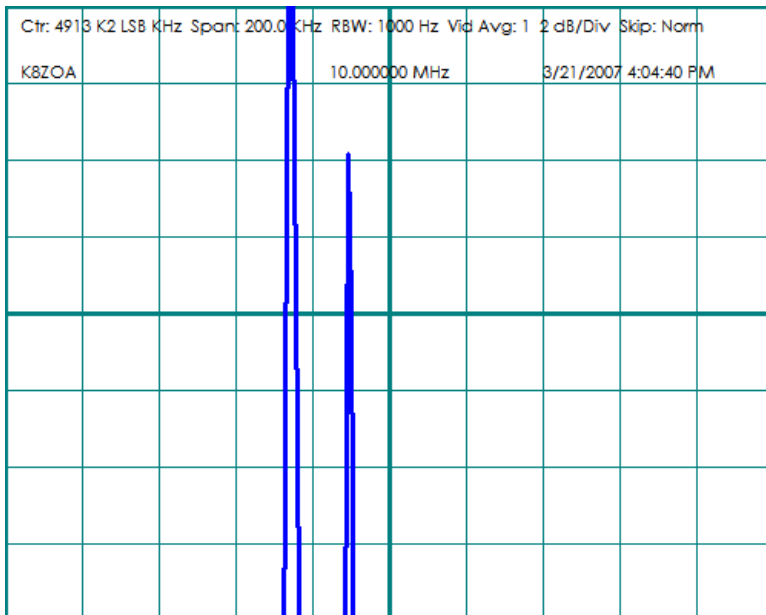

Jump to Frequency



Note: Frequency control and display is implemented only for the Elecraft K2 transceiver.

Once a frequency is entered into the Jump Frequency box, to command the K2 to that frequency, click on the Jump to Frequency button. Hitting the <Enter> key does not cause the frequency to be sent. This is a safety measure to prevent inadvertent frequency changes.

Enter Frequency
Force Jump to 1 KHz

Enter Frequency



Note: Frequency control and display is implemented only for the Elecraft K2 transceiver.

The yellow Enter Frequency box may be populated by two methods:

- Manual entry via the keyboard
- Automatic entry via mouse click on the display.

Manual Entry

You may enter the desired frequency from the keyboard in the normal fashion for Windows programs.

Data may be entered as kilohertz or megahertz. The program recognizes the entry as KHz if its value > 1000. Values <= 1000 are assumed to be in MHz. Decimal points are optional, and may be used as necessary to define the frequency to the desired precision.

Thus, all four of the following entries will command the K2 to 10.00000 MHz:

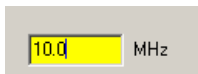
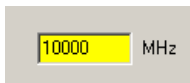

Entry via Mouse Click

If you have an Elecraft K2 connected to the Z90 Control software and if you have enabled Data Polling, the center frequency to which you are tuned appears at the center of the title block. The frequency is updated once per second, so it is possible that the displayed frequency will slightly lag behind if you quickly tuning the K2 across the band. The update frequency is limited to once per second to avoid burdening the K2's data processing functionality.

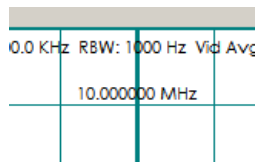

To automatically populate the Enter Frequency box with data from the display sweep, click the LEFT mouse button when the mouse pointer is within the display area (either normal trace display or waterfall display.) Clicking the LEFT mouse button will enter the frequency corresponding to the point on the screen under the mouse pointer. The frequency appears in the yellow edit window. Clicking on the Jump to Frequency button will automatically tune your K2 to this frequency.

Given the screen resolution, the limited number of pixels available and errors in mouse positioning, the frequency the K2 is tuned to via this process may not correspond exactly to the signal. Experience shows that it is generally quite close, and at most a small tweak to the K2's tuning dial is all that is necessary to put you on the correct frequency. To aid in tuning, it is possible to select an option to force the entered

frequency to be rounded to the nearest 1 KHz value.

Using the associate K2 mode with IF makes it easier to properly tune and read the frequency of off-the-air signals. Still, it necessary to understand the relationship between the K2's frequency dial and the visual display of signals in order to know where to click the mouse for automatic jump to frequency tuning to work the way you wish it to.

Carefully study the following figure to understand the relationship between the K2 dial frequency and the Z90 Control's normal trace display and waterfall display screens.

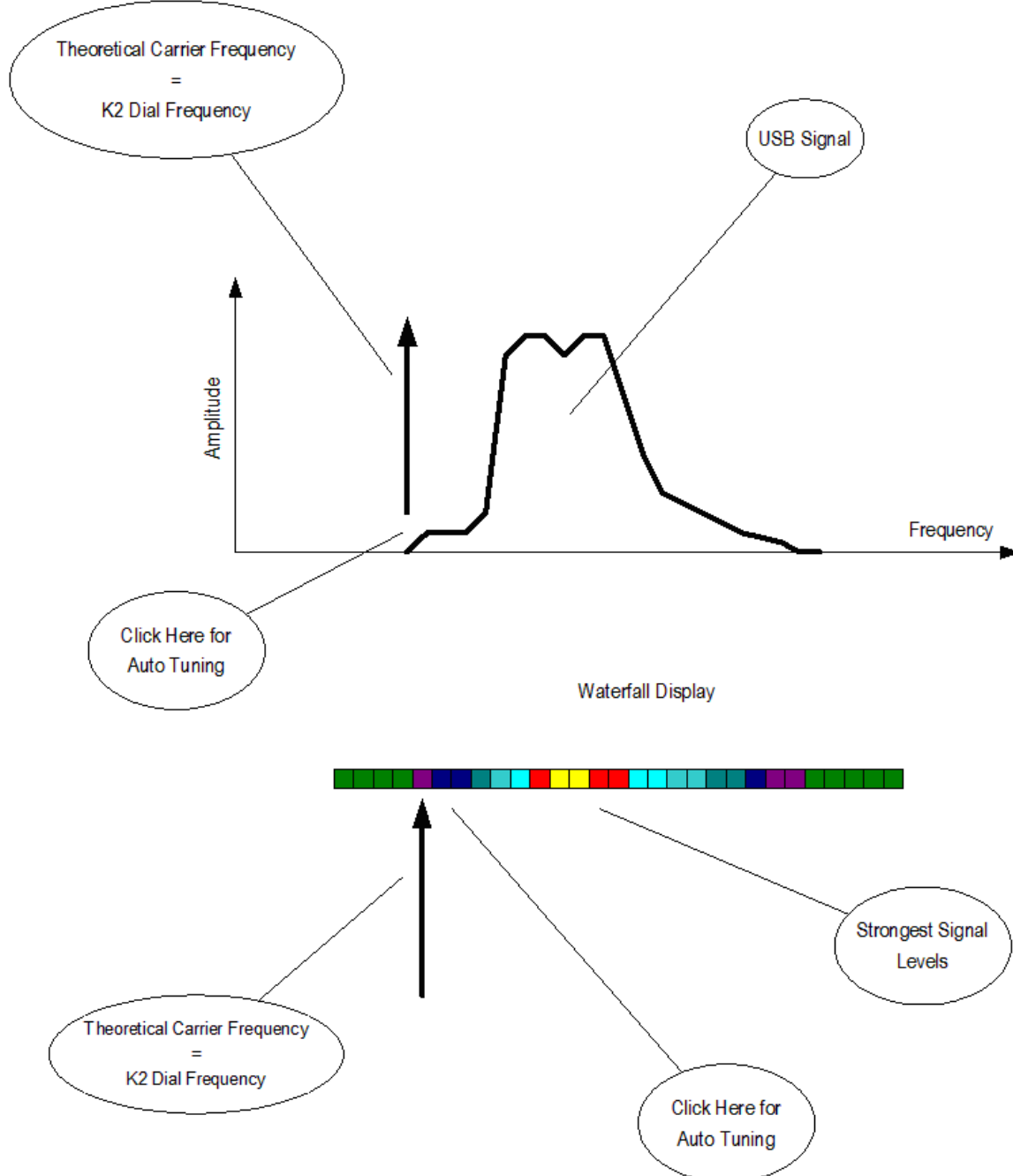

The idea behind mouse tuning is that the mouse should be positioned where the theoretical (in the SSB example) carrier is located, because that's how the K2 displays frequency.

The K2's dial shows the theoretical carrier frequency, while the spectrum analyzer (either normal trace mode or waterfall) shows the instantaneous amplitude versus frequency. In SSB, the carrier is suppressed and does not show in the spectrum display. Hence, you have to estimate its location by eye. For USB, the voice peaks will be about 1 KHz above the theoretical carrier, so the appropriate mouse click point is about 1 KHz below the strongest display frequency. For LSB, this is inverted--the voice peaks will be about 1 KHz below the theoretical carrier, so the appropriate mouse click point will be about 1 KHz above the strongest display frequency.

To make mouse tuning work the best for you, estimate where the theoretical carrier is, based on the intensity of the signal, either by color in

waterfall mode or from the shape of the spectrum if in spectrum trace mode. For SSB signals, these points will be above or below the areas of maximum signal strength. For CW, you will wish to select the maximum signal strength point.

Click the mouse at the appropriate point and the frequency will be transferred to the yellow frequency jump box. Then, click on the Jump to Frequency button to move the K2 to the desired point.

Jump to Frequency
Force Jump to 1 KHz

Force Jump to 1 KHz

Force Jump to 1 KHz

Note: Frequency control and display is implemented only for the Elecraft K2 transceiver.

To make mouse tuning easier, optional rounding to the nearest 1 KHz is available. (If enabled, rounding is applied to both mouse-entered and keyboard-entered frequencies.)

With the general usage of synthesized SSB transceivers in the amateur community, almost all SSB operation tends to be on frequencies with 1 KHz intervals. Hence, it's generally a safe bet that operation will be on 3830 KHz, not 3829.673 KHz, as might be the result of a mouse click on a waterfall or spectrum display. In this case, if 1 KHz rounding is enabled, the command will be transmitted to the K2 as 3830 KHz. Banker's rounding is implemented, with rounding up to even numbers.

My personal preference is to use 1 KHz rounding if tuning SSB signals, but to disable it for data and CW modes.

Edit Callsign

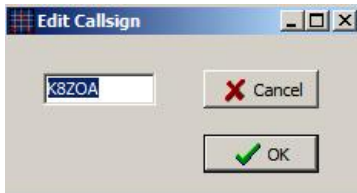

The Edit Callsign dialog is reached from Tools | Edit Callsign menu.

The purpose of this dialog is to permit you to program in your callsign or other identifier that will appear on the LCD screen (Z90 only) and in the title block of Z90 Control screens.

The maximum length is 10 characters.

The Cancel button will not change the current callsign setting.

The OK button will accept the changes and change the callsign stored in the Z90's non-volatile memory.

Select Comm Port

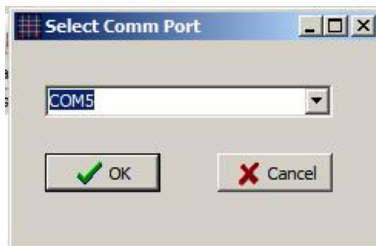

The Z90 connection serial communications port is defined from this dialog. It is reached from the Com Setup | Select Z90 Com Port menu item.

The current communication port will be highlighted when the dialog box appears.

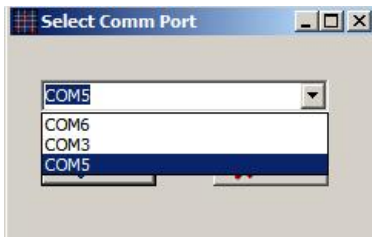

If you wish to select a different communications port, do so from this dialog box.

Cancel will revert to the communications port in use when entering the setup dialog. OK will accept the selected port, and close the port previously in use.

The communications parameters (115,200 b/s, 8 bit data, 1 stop bit, no parity, no hardware or software flow control) is set automatically by Z90 Control.

Set Custom IF

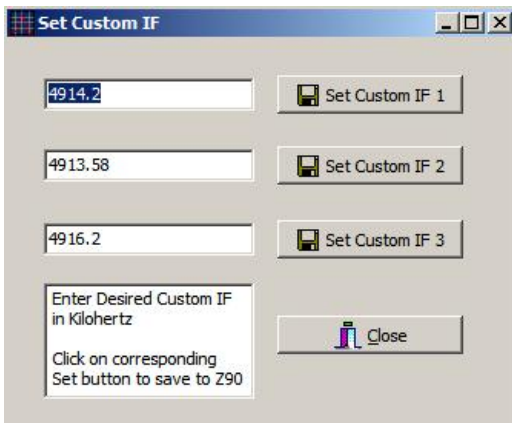

The Z90 allows users to define up to three custom IF frequencies. These frequencies are set from the Set Custom IF dialog. The dialog is reached from the Tools | Set Custom IF menu item.

When launched, the dialog shows the three currently defined custom IF frequencies. These may be edited or new values entered via the keyboard. When satisfied with the value, click on the associated Set button. The value will be saved to the Z90's non-volatile memory and that custom IF frequency will be made the IF presently in use.

Z90 Control version 1 required Custom IF values to be entered in Hz; **Version 2 requires the frequencies to be entered in KHz.**

If you use the K2 automatic mode link, all three custom IF frequencies must be devoted to your particular K2's CW, LSB and USB IF settings.

Associate K2 Mode with Custom IF CheckBox

Define Custom Span

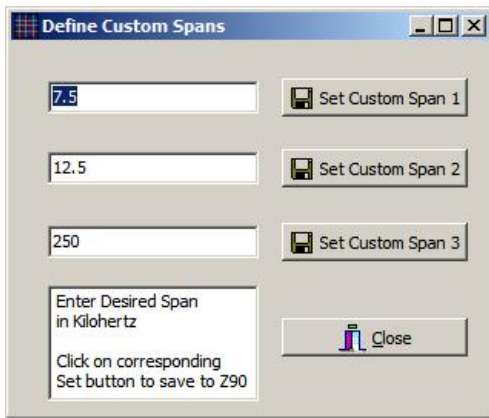

The Z90 allows users to define up to three custom span widths. These frequencies are set from the Set Custom Span dialog. The dialog is reached from the Tools | Set Custom Span menu item.

When launched, the dialog shows the three currently defined custom spans. These may be edited or new values entered via the keyboard. When satisfied with the value, click on the associated Set button. The value will be saved to the Z90's non-volatile memory and that custom span will be made the span presently in use.

Z90 Control version 1 required Custom Span values to be entered in Hz; **Version 2 requires the frequencies to be entered in KHz.**

Z90 Firmware Version



The Firmware Version dialog (reached from the Help | Show Firmware Version menu) displays the current firmware version loaded into the Z90.

Generate Frequency

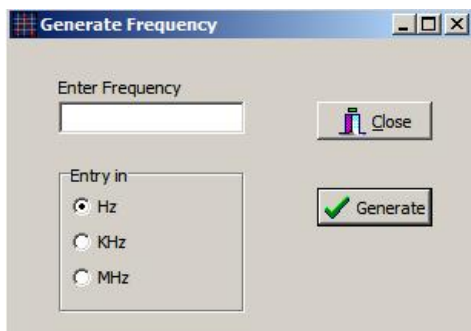

The Generate Frequency menu switches the Z90 to signal generator mode, permitting the user to enter the desired frequency in the dialog box shown above.

To generate a frequency, enter its value and select the format (Hz, KHz or MHz) and click on the Generate button. You may continue to enter frequencies with this same methodology.

To return to normal Z90 scan mode, click the Close button.

The close routine issues a Reset command to the Z90, which requires approximately 6 seconds to execute. Hence, it is normal for return to sweep mode to require this time.

Edit Display Properties

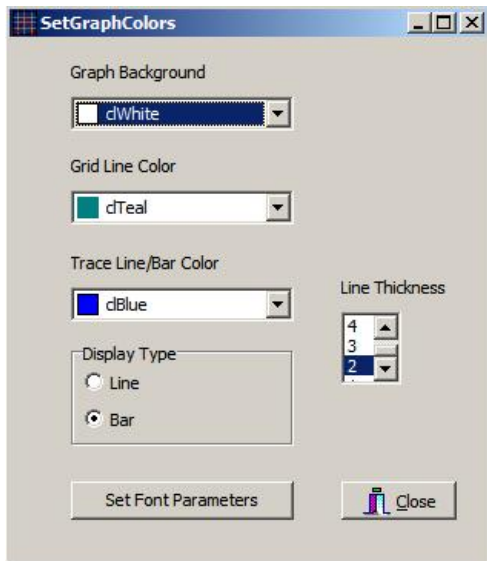

For details, see the following controls

Background Color Selection
 Grid Color Selection
 Display Type Line/Bar
 Line Thickness
 TraceColorBox ColorBox

Background Color

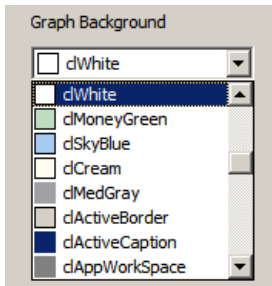

Background color selects the background color for the Amplitude/Frequency display.

Grid Color Selection

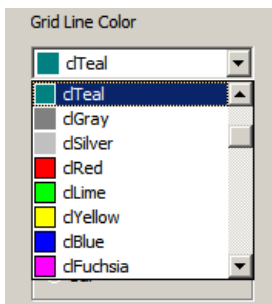

The Grid Line Color selector determines the color of the 8 x 10 grid line.

Display Type Line/Bar

Display Type

Line

Bar

Select either line (oscilloscope type) or bar display mode:

Line Mode

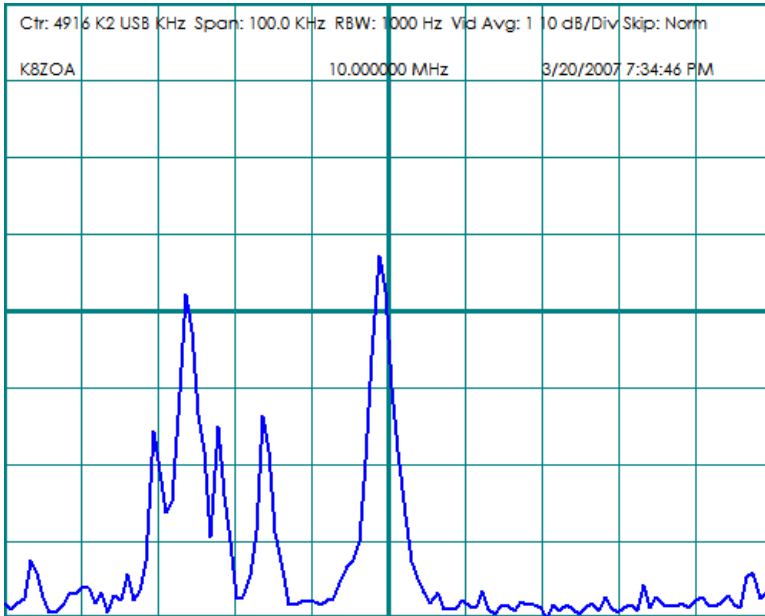

Bar Display Mode

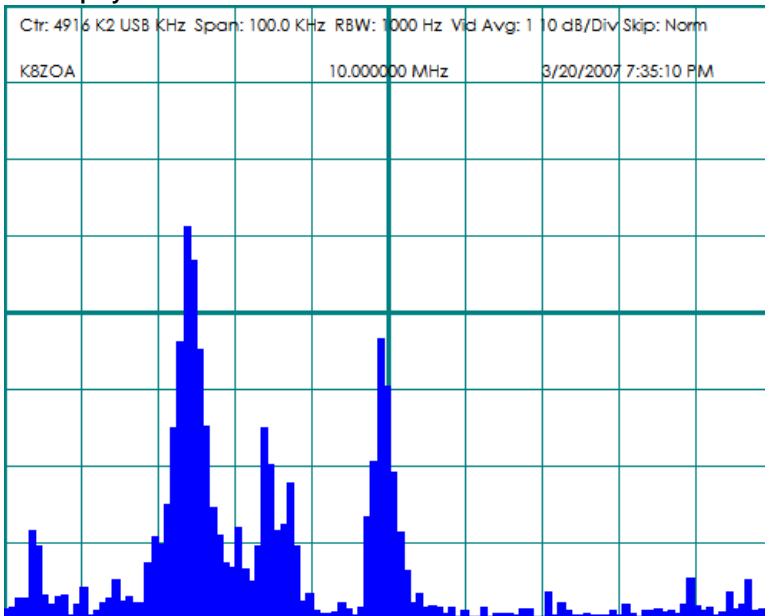

Line Thickness



The thickness of the trace when in line mode is adjustable from 1 (thin) to 10 (thick) via this control.

Line thickness = 1

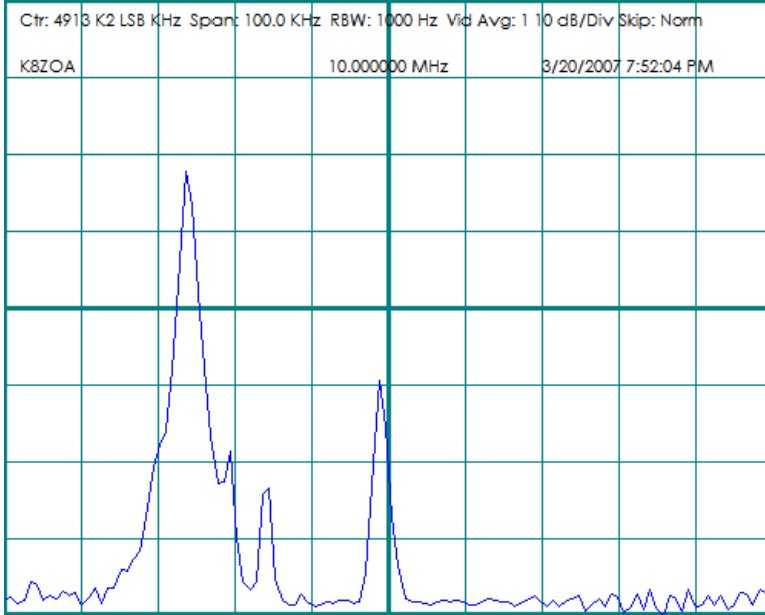

Line thickness = 8

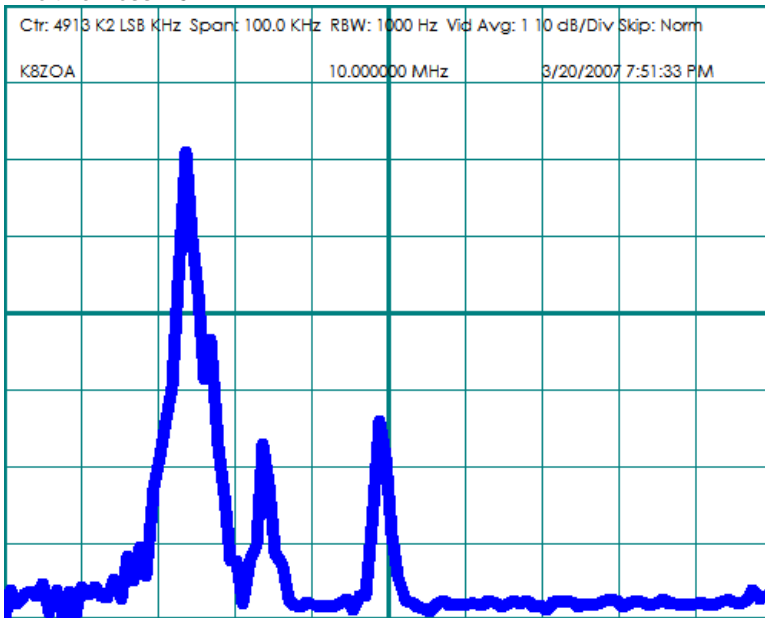

Line and Bar Color Selection

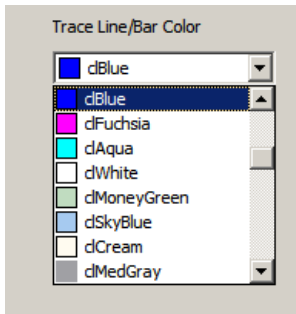

The trace line (and in bar mode, the bar color) is selected via the drop down box.

Send String to Z90

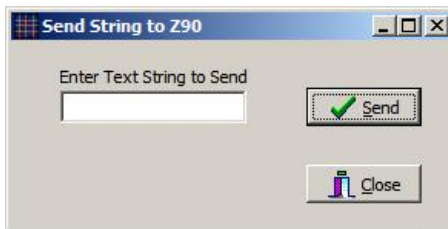

The Send String dialog allows you to send messages to the Z90. This function can be useful, should you find the Z90 in an unknown state or you wish to change a parameter not reachable via the normal Z90 Control structure.

The Send String function should not normally be used, as the Z90's response message may not always be properly understood by the Z90 Control software and may result in a mismatch between the Z90's state and Z90 Control's state, which can be rectified only by restarting both.

Setup Receiver Link

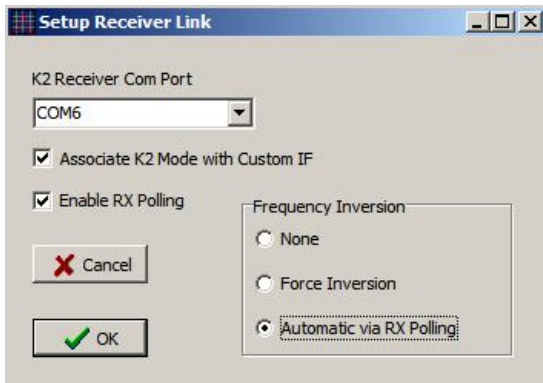

RXportList ComboBox
 Associate K2 Mode with Custom IF CheckBox
 Enable RX Polling CheckBox
 Frequency Inversion RadioGroup

The Setup Receiver link dialog controls if and how the software communicates with an Elecraft K2 transceiver.

For details, select from amongst the links above.

A detailed description of the K2 serial protocol is available from Elecraft at [Elecraft Home Page](#) The document title is *Elecraft K1O2 Programmer's Reference* and may be found in the Downloads section of Elecraft's page.

RX Port Selection

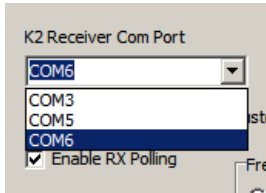

From the drop down list, select the communications port to which your K2 transceiver is connected. The program supplies the other communications port settings, such as speed (4800 b/s) bit setting and the like.

Associate K2 Mode with Custom IF

Associate K2 Mode with Custom IF

Elecraft's K2 transceiver is a single-conversion design, with one filter set used for USB, LSB and CW. This, by necessity, means that the BFO must shift from one side of the filter to the other as the mode changes between USB and LSB. In addition, on the bands from 1.8 MHz through 18 MHz, the K2's local oscillator is placed 4.915 MHz above the tuned frequency (high side injection) whilst on 21 - 28 MHz, the local oscillator is below the tuned frequency (low side injection). This inverts the sense of the received frequency when looked at in the IF, where the Z90 attaches, and also means that the K2's BFO's relationship with mode is inverted on the 21-28 MHz bands compared with the ones below 21 MHz. In order to keep the receiver indicated frequency constant whilst shifting modes, the K2's designers program in a local oscillator shift that tracks the BFO versus mode changes.

What this means is that the Z90 (or any other spectrum analyzer) connected to the K2's IF will show a different "pip" location for the same frequency when the K2's mode button is cycled from LSB to USB to CW. This is shown below.

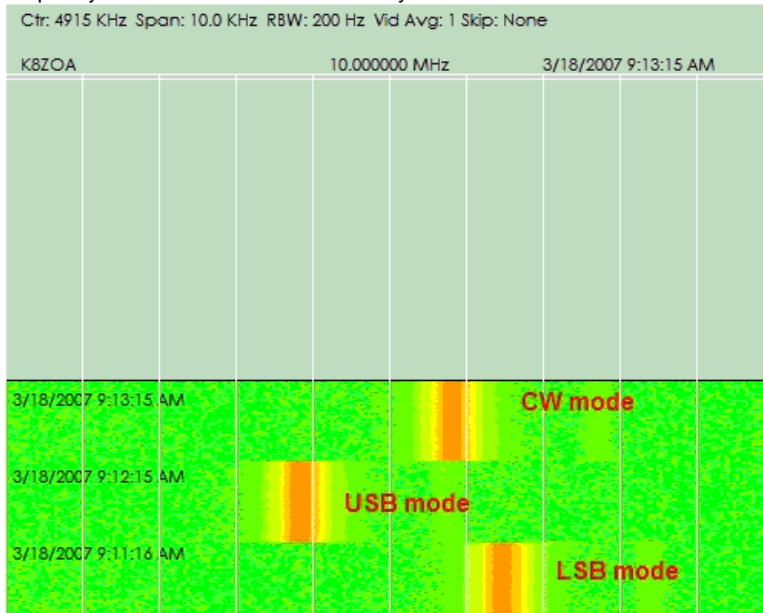

This data is taken with the K2 tuned to 10 MHz, and the signal seen is from WWV. The difference between USB and LSB mode is approximately 2.5 KHz. CW mode is between the USB and LSB frequencies.

One way to look at the K2's conversion scheme is to consider that it has three IF frequencies, not just one. Thus, by programming three custom IF frequencies, it is possible to see little or no shift in the spectrum display when cycling from mode-to-mode, providing, of course, the corresponding custom IF is selected.

Here is the result after defining three custom IF frequencies for my K2, one for USB, one for LSB and one for CW modes. The blips are the brief transition period after the K2 switches modes but before the new IF selection in the Z90 takes effect. Note that there is little, if any, frequency difference amongst the three modes.

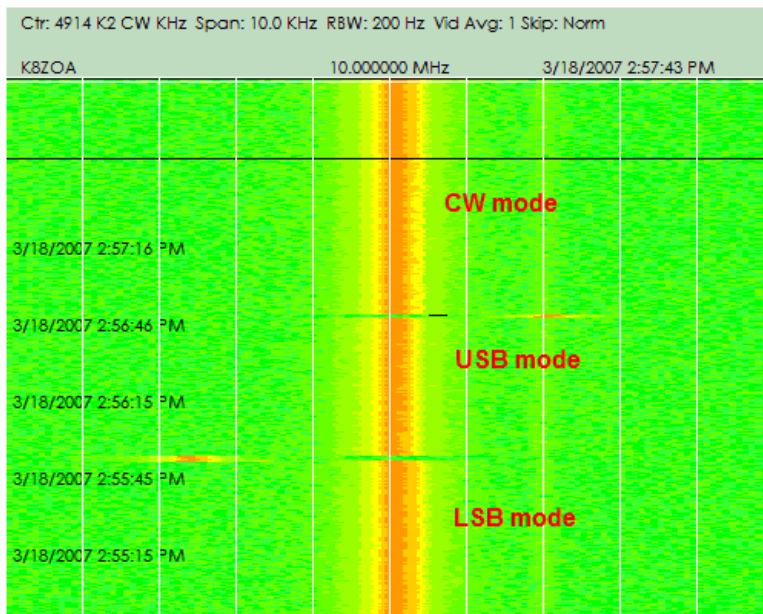

Z90 Control version 2 includes automatic linkage so that if your K2 is connected to the Z90 software and if you have defined the three custom IF frequencies, the software will automatically select the correct IF and apply it, and will also automatically apply the necessary reversal for 21 MHz and above, compared with lower frequencies.

To use the automatic IF selection feature, set up the operating parameters using the following steps:

1. Find a strong, steady CW or AM signal below 20 MHz. This can be WWV at 10 MHz, or an AM shortwave broadcast station, or a signal generator input to the K2, with a known frequency. This example assumes you are using WWV at 10 MHz.
2. Set the K2 to 10.00000 MHz. Set the Z90-Control software to waterfall mode and span 10 KHz, 4915 KHz IF. Switch the K2 amongst USB, LSB and CW modes. You should note a shift of two KHz or so between USB and LSB, with CW being between these two.
3. Using the TOOLS | DEFINE CUSTOM IF menu, start the Set Custom IF dialog. It will look similar to the following, although the values entered in the three edit boxes will be different.

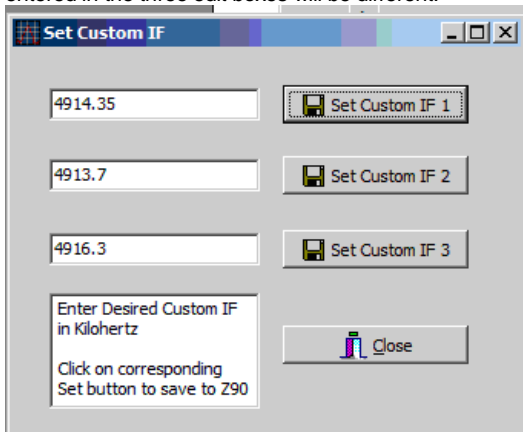

4. Enter the values shown above into the three edit boxes. These values should be close, but will not be exact.
5. Set the K2 to CW mode and observe the waterfall track, noting how far it is displaced from the center line. If perfectly centered, the red line should be exactly split by the center grid line. Adjust the value for Custom IF 1 up or down, clicking on Set Custom IF1 after each change, until the signal is exactly centered on the center grid.
6. Set the K2 to LSB mode and repeat this process, entering your corrected values for Custom IF 2. Click on Set Custom IF 2 after each entry until the track is centered.
7. Set the K2 to USB mode and repeat this process, entering your corrected values for Custom IF 3. Click on Set Custom IF 3 after each entry until the track is centered.
8. Close the Custom IF dialog box and shut down Z90-Control.
9. Locate the Z90-Control program's initialization file, Z90.INI. This should be in the directory described during the installation process, c:\documents and settings\

```
[IFTags]
Tag0=
Tag1=
Tag2=
```

Tag3=
 Tag4=
 Tag5=
 Tag6=
 Tag7=
 Tag8=
 Tag9=
 Tag10=

After each TagN= line, you may enter a brief text note that will appear after the IF frequency in the drop down box.

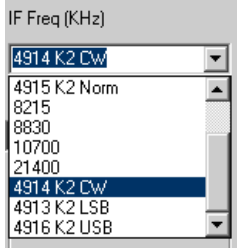

Although not necessary, it will greatly assist you in making manual IF frequency selections if you add a corresponding note. Here is how I've annotated my setup file.

[IFTags]

Tag0=
 Tag1=
 Tag2=
 Tag3=K2 Norm
 Tag4=
 Tag5=
 Tag6=
 Tag7=
 Tag8=K2 CW
 Tag9=K2 LSB
 Tag10=K2 USB

You can use any other text you find helpful; and you can add notes for the other IF frequencies, e.g, for 8830 (Tag5) you could add "Kenwood."

The association between IF frequency and Tag is:

Tag0 =450
 Tag1 =455
 Tag2 =500
 Tag3 =4915
 Tag4 =8215
 Tag5 =8830
 Tag6= 10700
 Tag7 =21400
 Tag8=Custom 1
 Tag9=Custom 2
 Tag10=Custom 3

10. Do not use quotation marks around the text; the program knows that whatever follows the equals sign is text. When you have finished adding the annotations, save the INI file before exiting Notepad. The INI file should be saved as a simple text file, should your editing program have other options.

11. Restart Z90-Control and drop down the IF frequency list. Your notes should appear to the right of the frequency value.

12. To enable automatic tracking of mode and selection of the corresponding custom IF, you must enable this feature in Setup RX Link via the Associate K2 Mode with Custom IF check box.

13. In order for the association data to be provided and for the program to have all the information necessary to make an intelligent selection of IF frequencies, you must also select "Enable RX Polling" and "Frequency Inversion - Automatic via RX Polling." Your selection should match the above illustration. Your selections are saved in the INI file and will be in effect until you manually alter them.

14. Of course, none of this will work unless your K2 is connected to the computer and communications have been established between Z90 Control software and your K2's serial data port. Don't forget that the K2's DB9 connector has a special pin connection and the cable supplied with your K2 must be used to connect it to your computer's serial port.

Enable RX Polling

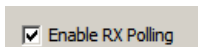

When selected, the software queries an attached Elecraft K2 transceiver once every 1000 milliseconds. The query string "IF;" is sent, which

returns the status of VFO A, VFO B, RIT, current operating mode and other information. The response is used by Z90 Control for four purposes:

1. To read the tuned frequency for display in the center of the swept display images.
2. To operate the automatic frequency inversion function, if enabled.
3. To link mode to custom IF frequency, if enabled
4. To provide status information when sending frequency jump information to the K2, to preserve current VFO and RIT settings.

To use any of the above functions, you must enable RX polling.

Frequency Inversion Option

Many radio receivers invert the frequency sense in their IF chains. Some, such as Elecraft's K2, invert on some bands and not on others. Others, such as the Racal RA7690/GM invert the 455 KHz IF output on all bands.

The Z90 follows the spectrum analyzer convention of sweeping from low to high, *i.e.*, higher frequency signals appear to the right of lower frequency signals. This can cause confusion when a Z90 is connected to a receiver with an inverting conversion scheme, which causes higher frequencies to appear to the left of lower frequencies.

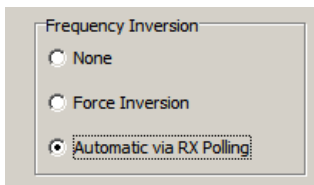

Z90 Control release 2 provides three options to display frequencies:

1. No change in the data from the Z90. Signals at the Z90's input port that are lower frequency appear at the left of the display screen, higher frequencies at the right.
2. Forced inversion; lower frequencies are shown at the right and higher frequencies at the left. This restores the correct sense when the Z90 is connected to an inverting receiver.
3. Automatic inversion; based on polling data from an Elecraft K2 transceiver, the software automatically inverts the frequency display sense on those bands where it is necessary to preserve normal display operation. If enabled, and connected to a K2, higher frequencies will always be displayed to the right of a lower frequency, regardless of band setting.

If you intend to use the automatic frequency read and jump features of Z90 Control, you must operate with Automatic Frequency Inversion enabled.

Note that this function only alters the Windows display the Z90's LCD always displays frequency sense based on the frequencies at the input connection; left = lower; right = higher.

More detail on why some receivers invert frequencies is provided below, extracted from Clifton Laboratories web site FAQ.

Frequency Inversion

Question:

When connected to my K2, on the higher bands, signals below the tuned frequency display to the left of center, but on lower bands signals below the tuned frequency display to the right of center. Is this normal? [This topic is not limited to the K2. JRS]

Answer:

The short answer is "yes" this is normal. Let me provide some detail, however.

The Z90's current firmware always shows a lower input frequency to the left of center and higher input frequencies to the right of center. This is how a real spectrum analyzer works; the frequency sweeps left to right, with the starting, lower, frequency at the left.

However, the relationship between the RF input frequency and the IF frequency depends on the receiver architecture. Let's look at an example with a double conversion, up-converting receiver design using the arrangement shown below.

Typical Up-Conversion Receiver Panadapter Inversion/Normal Depending on Frequency Plan and Connection Point

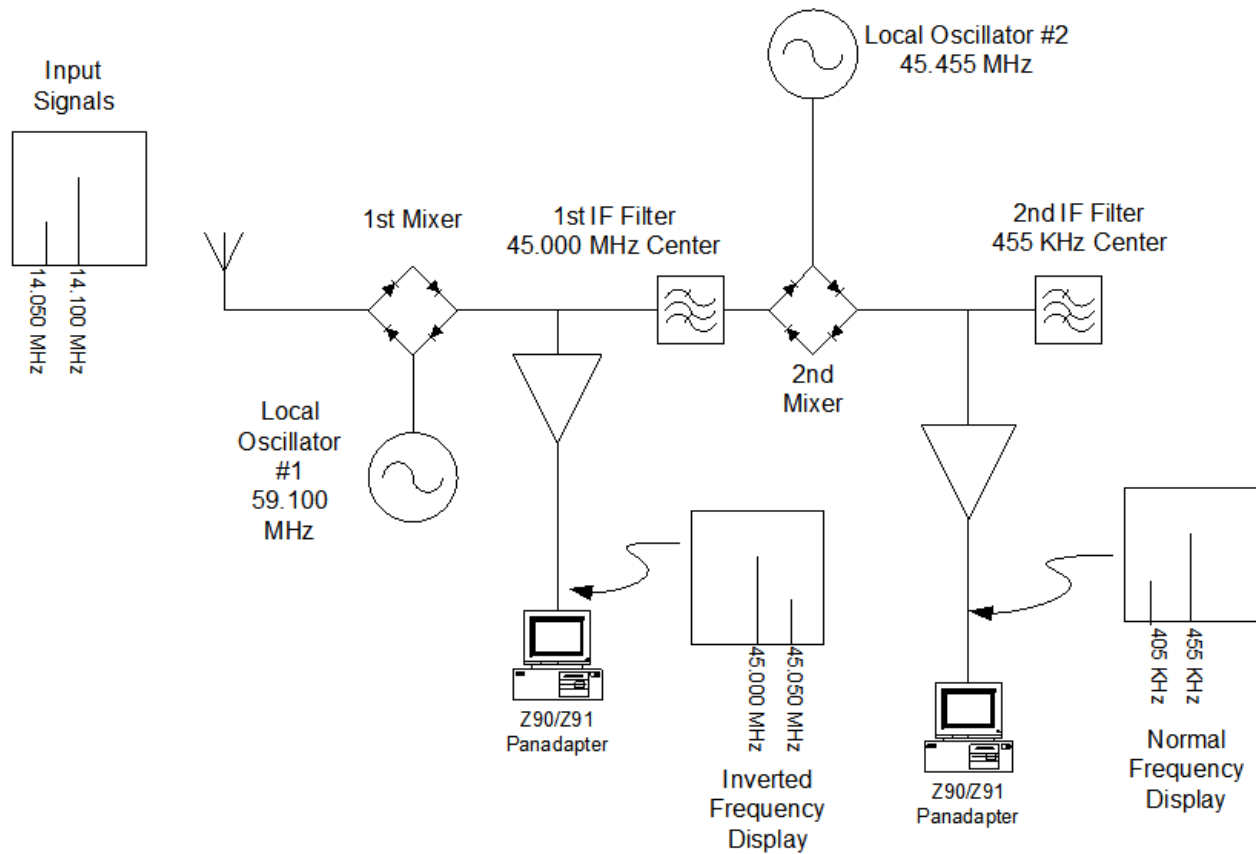

The receiver is tuned to 14.100 MHz and there's a second, weaker, signal at 14.050 MHz. In this example, the receiver has two Z90's connected, one at the 1st (45 MHz) and one at the second IF (455 KHz).

The receiver architecture inverts the frequency band with each conversion stage. Thus, the 1st IF frequency band is a mirror image of the frequency to which the receiver is tuned; signals lower in frequency than that to which the receiver is tuned are translated to a higher 1st IF frequency. A Z90 connected to the 1st IF will therefore show the lower frequency (considered with respect to the 14 MHz band) as to the right of center.

If the Z90 is connected to the 2nd IF, the 2nd mixer's inversion cancels the 1st mixer's inversion so the Z90's display will have the correct display-to-frequency relationship.

Some receivers invert their IF output and others don't. For example, my Watkins Johnson HF-1000's 455 KHz IF output is inverted with respect to the original RF input. My Kenwood TS940's 8830 KHz IF output, however, provides correct sense; lower RF frequencies correspond to lower IF output frequencies. However, an up converting receiver always inverts the 1st IF (A bit of working with the math will convince you this is necessary to avoid spurious signal problems,..)

Now, let's look at the K2, which is a single conversion receiver, with high side injection on some bands and low side injection on other bands.

We'll start with the 10 meter band. The K2's local oscillator runs below the tuned frequency (low side injection). The IF output tracks the RF input; frequencies below the one the receiver is tuned to are translated into lower IF frequencies and the Z90 displays the visual image of the signal correctly with respect to left/right of center.

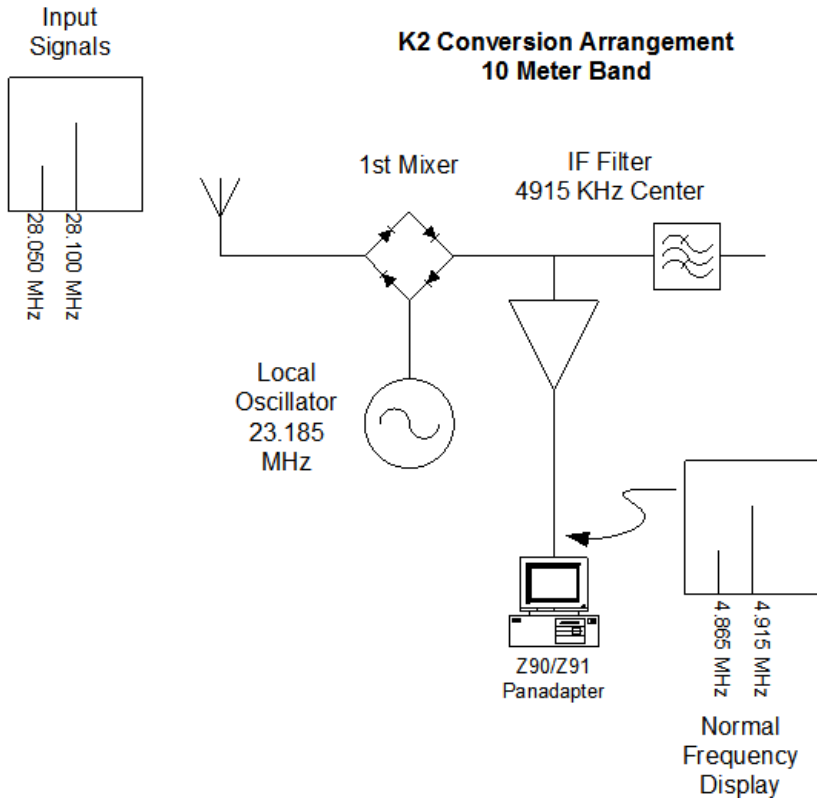

Now, suppose we switch to the 80 meter band. Again, we'll suppose the K2's receiver is tuned to 3.6 MHz and there's one other signal on the band, a weaker one at 3.550 MHz.

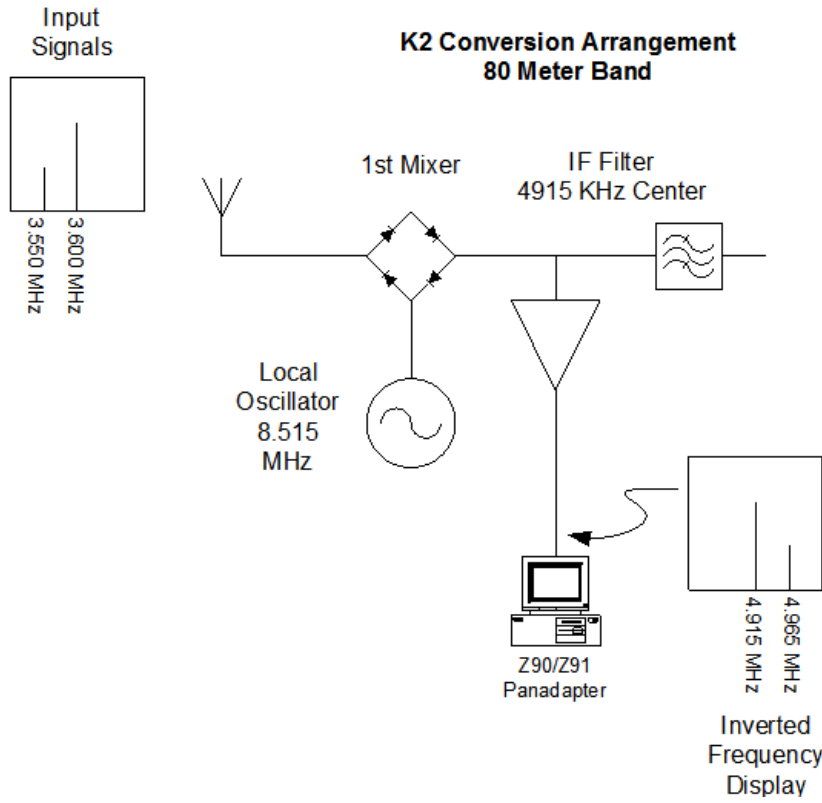

On the 80 meter band, the K2's local oscillator runs above the received frequency (high side injection) and hence the IF frequencies are mirror imaged about the tuned frequency. Signals that are below the tuned frequency appear on the Z90 right of center.

Now to the user, all of these frequency conversion schemes are totally invisible--the K2's microprocessor adjusts the BFO and frequency readout and tuning steps to make the receiver act consistently, regardless of whether high-side or low-side injection is used for any particular frequency band.

But, the Z90 displays the actual IF frequency and hence will show a normal display on some bands and an inverted frequency sense on other bands.

Design Waterfall Colors

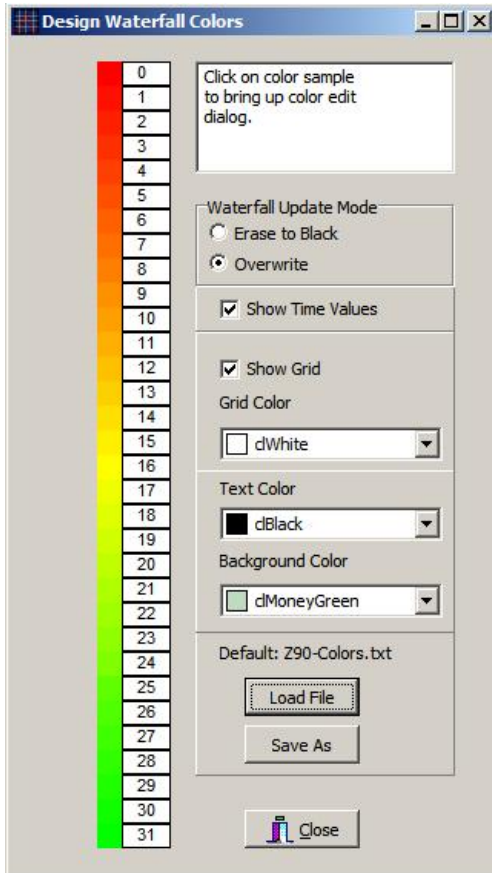

This dialog lets you define the waterfall display parameters. The text font is set from the Amplitude/Frequency setup box and is the same in both display modes.

User-settable parameters are:

Waterfall Update Mode:

The waterfall display shows 350 sweeps. When the 351st sweep arrives, the action taken depends on which Waterfall Update Mode option is selected:

- Erase to Black--All current sweeps are erased and the display area is reset to the current background color. New sweeps start at the bottom.
- Overwrite--Current sweeps stay in place. New sweeps start at the bottom. A black line shows the new sweep insert point.

Show Time Values

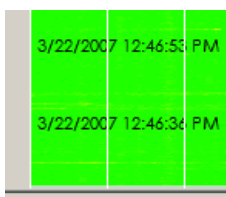

When Show Time Value is enabled, the left side of the waterfall display shows the sweep time. Time hacks are added every 50 sweeps and show the full date and time, in the presently selected text color.

Show Grid

Show Grid, when enabled, causes vertical grid lines to be displayed that divide the waterfall area into 10 segments.

Grid Color

Allows the user to set the grid color. The drop down box provides the color selection.

Text Color

The Text Color selection box defines the text color for the title block, time/data hacks and also the waterfall scale.

Background Color

The background color is the color in the title block and also the color that appears when the waterfall display is erased or reset.

Load File

The waterfall color scale is saved in a text format file. The waterfall color scale file loaded at startup is the one named "Z90-Colors.txt" and the file format is described in this help file at Waterfall Color File Format. You can load a different color file from this button. The file will be used for the duration of the session but when you open Z90 Control next time, Z90-Colors will be loaded. Hence, if you define a new waterfall color palette and wish that to be used automatically, you should save that file as "Z90-Colors.txt".

Save As

Changes in the waterfall color scale can be saved from this button. If you define a new waterfall color palette and wish that to be used automatically, you should save that file as "Z90-Colors.txt".

Close

The close button closes the edit dialog.

Editing Colors

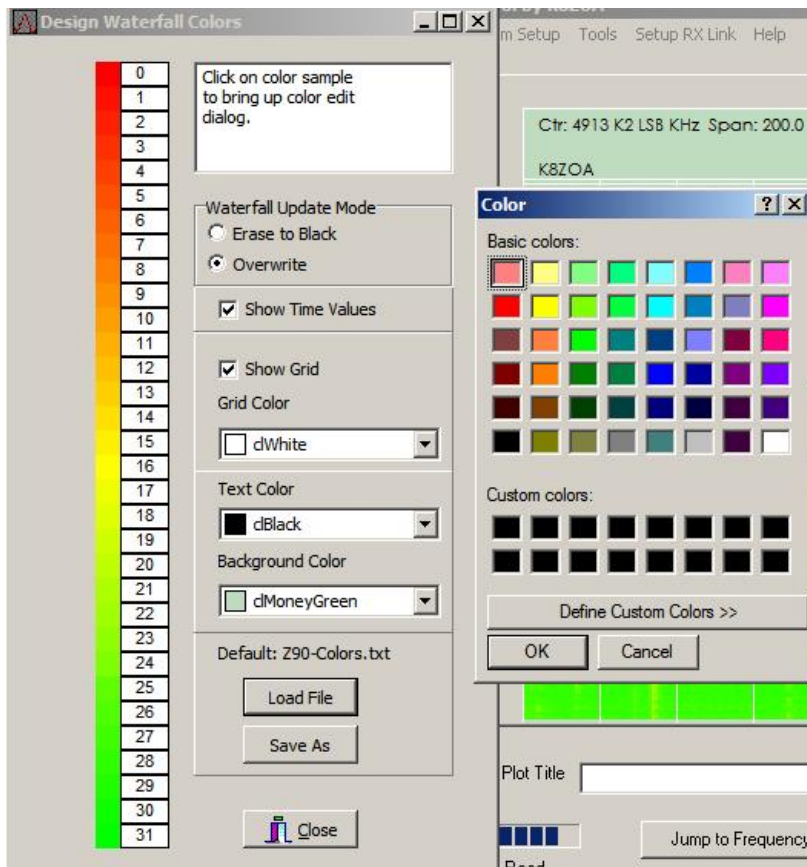

The waterfall color arrangement has 32 steps, 3 dB per step. Each color is individually editable.

To edit a color, place the mouse on either the color or the number step and click the LEFT mouse button. A color dialog box will appear for that color step.

Your color edits will be used until you exit Z90 Control. If you wish these changes to be saved, use the Save As option. Note that the waterfall color scale file loaded at startup is the one named "Z90-Colors.txt" and the file format is described in this help file at Waterfall Color File Format. You can load a different color file from this button. The file will be used for the duration of the session but when you open Z90 Control next time, Z90-Colors will be loaded. Hence, if you define a new waterfall color palette and wish that to be used automatically, you should save that file as "Z90-Colors.txt".

Waterfall Color File Format

Waterfall Color File Format

The waterfall color file is saved as a standard text file. The file is located in the same folder as the Z90.INI file.

There are 32 color steps in the color file palette and each step is defined by three red, green and blue color values. RGB values run from 0...255, one data entry per line. The color sequence is strongest signal ... weakest signal.

Here are the first nine lines in the default Z90-Color.txt file:

```
255
0
0
255
16
0
255
32
0
```

These values should be understood as:

```
<for color level 0...-3 dB>
Red = 255
Green = 0
Blue = 0
<for color level -3 ... -6 dB>
Red = 255
Green = 16
Blue = 0
<for color level -6...-9 dB>
Red = 255
Green = 32
Blue = 0
```

The waterfall color scale file loaded at startup is the one named "Z90-Colors.txt" and the file format is described in this help file at Waterfall Color File Format. You can load a different color file from this button. The file will be used for the duration of the session but when you open Z90 Control next time, Z90-Colors will be loaded. Hence, if you define a new waterfall color palette and wish that to be used automatically, you should save that file as "Z90-Colors.txt".