

# Z10022A

## Medium Wave Band High Pass Filter

---

Operation Manual

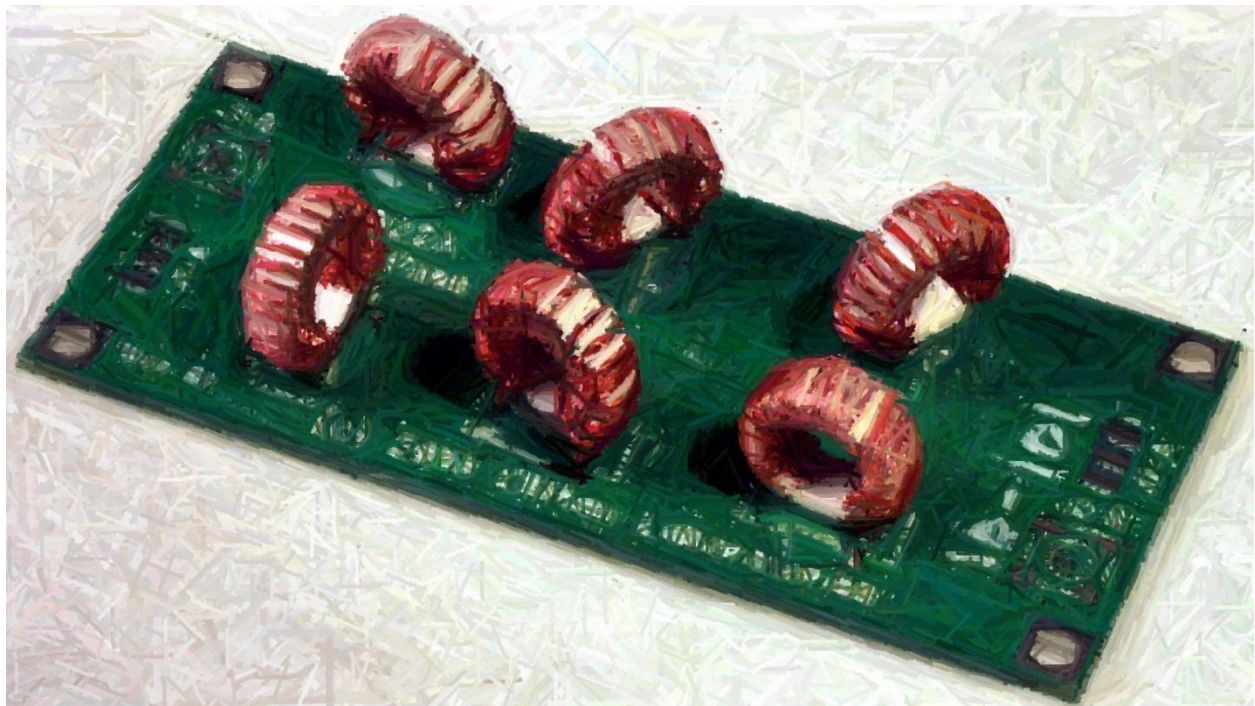

*Revised 23 November 2010*

*Clifton Laboratories*

*7236 Clifton Road*

*Clifton, VA 20124*

*(703) 830 0368*

[www.cliftonlaboratories.com](http://www.cliftonlaboratories.com)

## Contents

Model Z10022A Medium Wave Band High Pass Filter .....	2
Trademarks and Copyright.....	2
Warranty .....	2
Description .....	3
Specifications .....	3
Photographs.....	4
Mounting and Connectors .....	5
Mounting.....	5
Connectors .....	5
Frequency Response .....	6
Input VSWR .....	8
Schematic.....	9

# Model Z10022A Medium Wave Band High Pass Filter

*Revised 23 November 2010*

*(c) 2010 Jack R. Smith d/b/a/ Clifton Laboratories.*

## Trademarks and Copyright

Material in this document copyrighted © 2010 Clifton Laboratories. All rights reserved. It is provided to allow the Z10022A purchasers to maintain their equipment and such other purposes as may not be prohibited by law.

## Warranty

This warranty is effective as of the date of first consumer purchase.

**What is covered:** During the ninety (90) days after date of purchase, Clifton Laboratories will correct any defects in the Z10022A due to defective parts or workmanship (if purchased as an assembled unit) free of charge (post-paid). You must send the unit at your expense to Clifton Laboratories, but we will pay return shipping. Clifton Laboratories' warranty does not extend to defects caused by your incorrect assembly or use of unauthorized parts or materials or construction practices.

**What is not covered:** If the Z10022A is purchased as a kit, this warranty does not cover correction of assembly errors or misalignment; repair of damage caused by misuse, negligence, or builder modifications; or any performance malfunctions involving non-Clifton Laboratories accessory equipment. *The use of acid-core solder, water-soluble flux solder, or any corrosive or conductive flux or solvent will void this warranty in its entirety.* Damage to the Z10022A or equipment connected to it caused by lightning strikes is not covered under the warranty. Whether purchased as an assembled unit or as a kit, also not covered is reimbursement for loss of use, inconvenience, customer assembly or alignment time, or cost of unauthorized service.

**Limitation of incidental or consequential damages:** This warranty does not extend to non-Clifton Laboratories equipment or components used in conjunction with our products. *Any such repair or replacement is the responsibility of the customer. Clifton Laboratories will not be liable for any special, indirect, incidental or consequential damages, including but not limited to any loss of business or profits.*

**Under no circumstances is Clifton Laboratories liable for damage to your equipment connected to the Z10042AV resulting from use of the Z10022A, whether in accordance with the instructions in this Manual or otherwise.**

## Description

The Z10022A is a receive-only 9<sup>th</sup> order 1 dB Chebyshev high pass filter with a nominal cutoff frequency of 1800 KHz.

The Z10022A is intended to be used to prevent a shortwave receiver from overloading due to strong signals from AM broadcast band (Medium Wave) in the 530-1700 KHz range.

Frequencies below 1800 KHz are suppressed by the Z10022A.

An alternative to the Z10022A—where frequencies below 500 KHz are also of interest—is Clifton Laboratories' Z10020A band-reject filter. The Z10020A passes signals up to approximately 500 KHz and above 1800 KHz, suppressing signals in the AM broadcast band between these two frequencies.

The Z10022A is available as a printed circuit board for installation in the purchaser's enclosure or as a stand-alone filter in an enclosure, equipped with connectors.

## Specifications

Printed circuit board dimensions: 3.5 x 1.5 inches (88.9mm x 38.1mm)

Height: Approximately 1 inch (25mm)

Filter Type: 9<sup>th</sup> order 1 dB Chebyshev.

Input and Output Impedance: 50 ohms

Cutoff Frequency: 1.8 MHz

Loss at Cutoff Frequency: Typical 1.6 dB

Ultimate Rejection: > 90 dB, typically > 100 db

Input VSWR: Less than 3:1 1.8-30 MHz.

Connectors: PCB has pads suitable for direct connection or 0.1" pin headers or SMA vertical mount connectors. When installed in enclosure, BNC, SMA, N and UHF connectors are available.

Power Rating: Receive only design. Recommended power level not to exceed +20 dBm.

Photographs

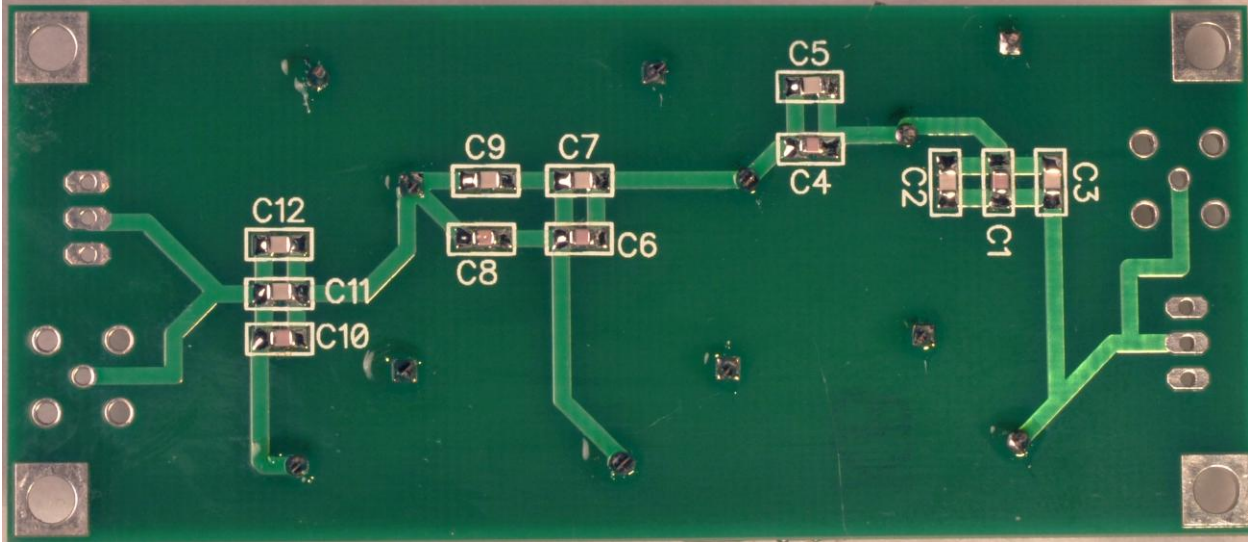
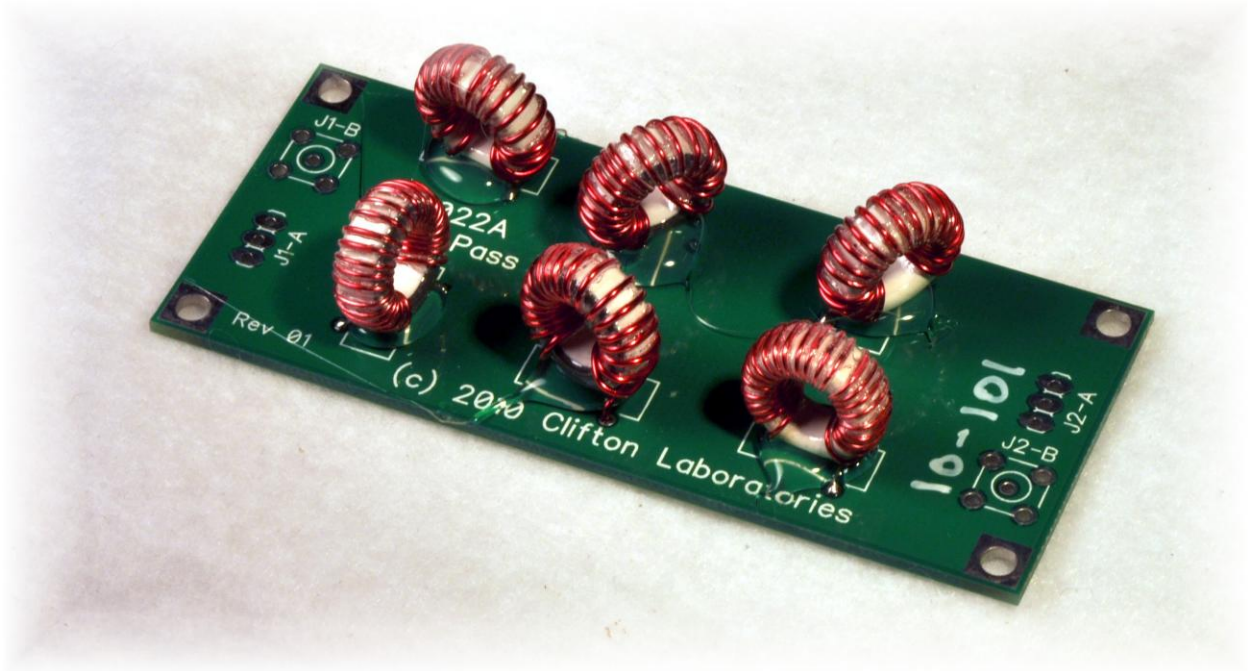

## Mounting and Connectors

### Mounting

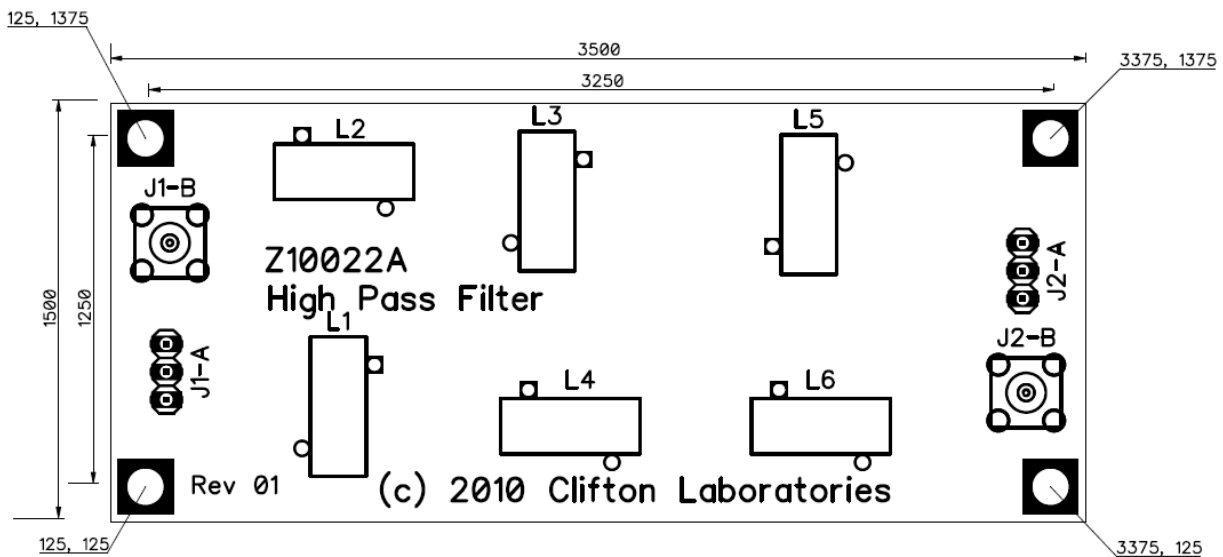

The Z10022A has four mounting holes, 0.125 inches diameter (3.18mm) suitable for 4-40 hardware.

In order to obtain maximum stopband rejection, Clifton Laboratories recommends a minimum of 0.5 inches (12.7mm) clearance between metallic surfaces and any inductor on the Z10022A. Greater clearance, up to 1.0 inches (25.4mm) is desirable if possible.

### Connectors

The Z10022A input and output has two optional connection types. J1-A and J2-A are suitable for direct solder connection (center pad is center conductor; outside pads are ground) or a 0.1 inch spaced (2.54mm) square pin header.

A suitable three-pin connector (female) is Sullins Connector Solutions part number PPPC031LFBN-RC, available from DigiKey, stock number S7036-ND



Matching pin header (male) is Sullins Connector Solutions part number PBC36SAAN, available from DigiKey, stock number S1011E-36-ND. This is a 36 pin breakaway part that snaps into 3-pin sections.



Connection positions J1-B and J2-B are for a vertical SMA connector, such as Tyco Electronics part number 5-1814832-1, available from DigiKey, stock number A97594-ND.

## Frequency Response

Typical frequency response plots of a Z10022A are below. Some unit-to-unit variation exists so the specific performance seen in this plot may not be seen in every filter.

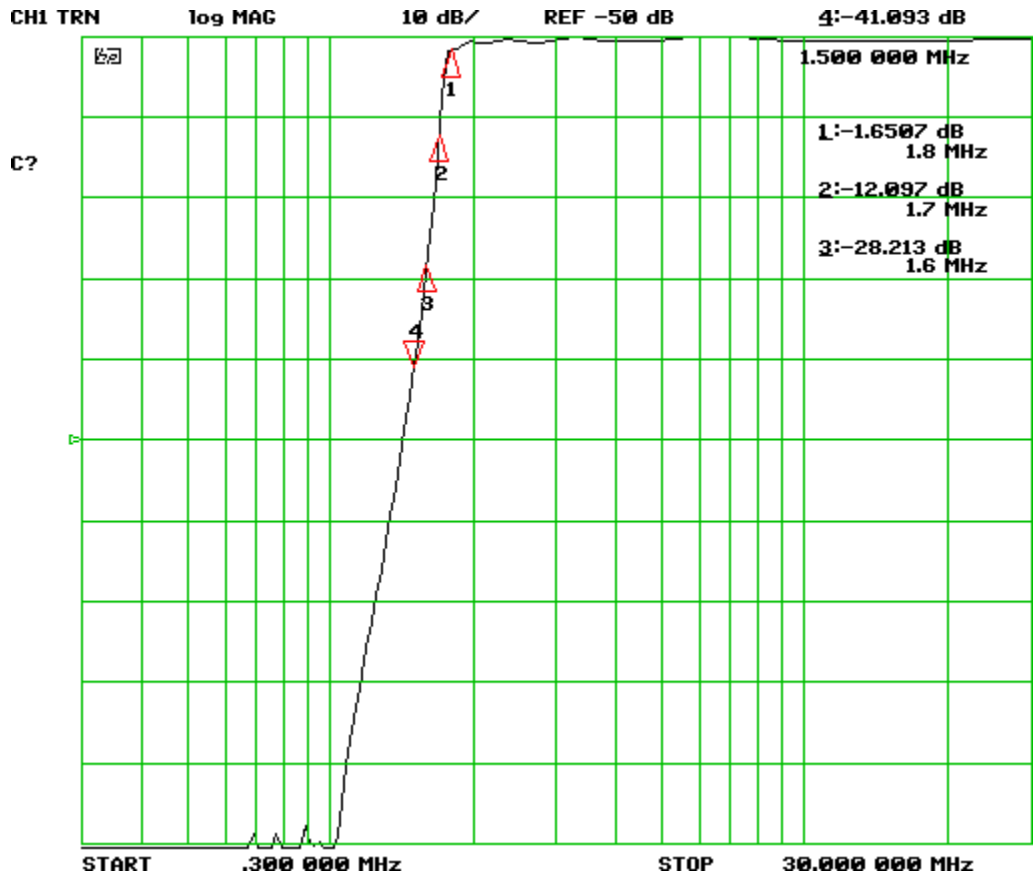

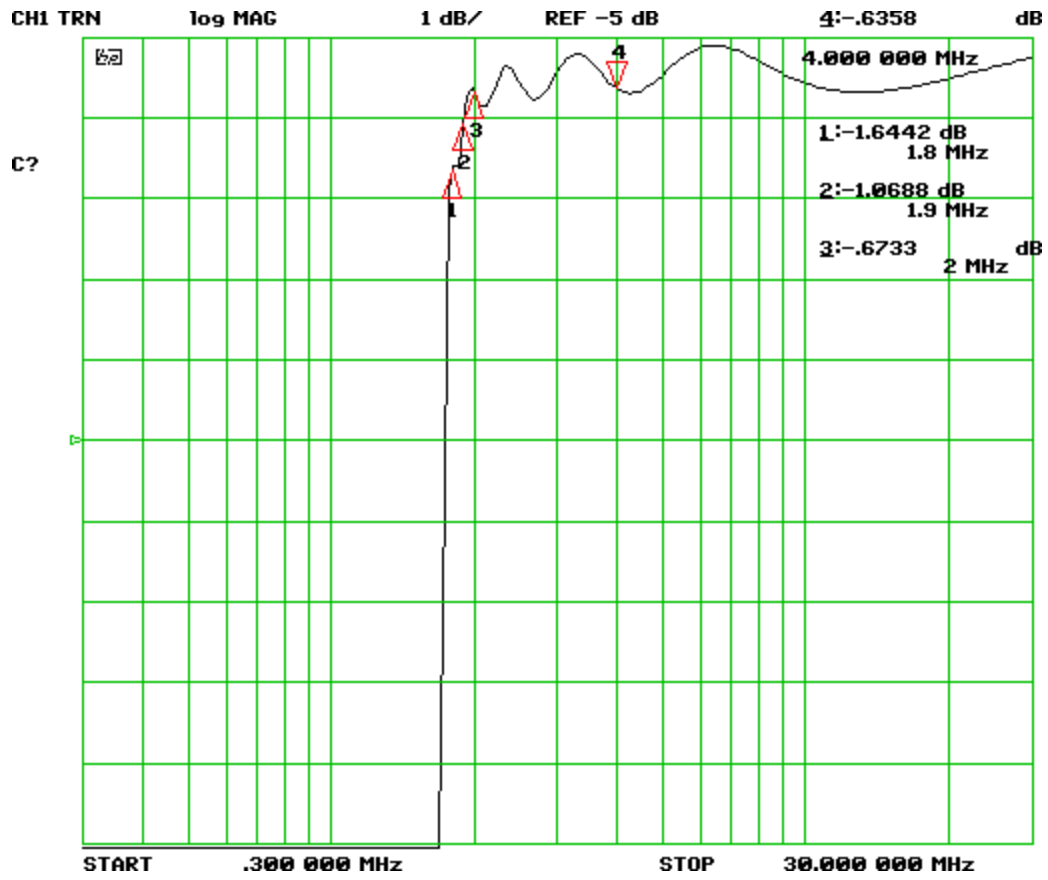

## Input VSWR

Typical VSWR of a Z10022A are below. Some unit-to-unit variation exists so the specific performance seen in this plot may not be seen in every filter.

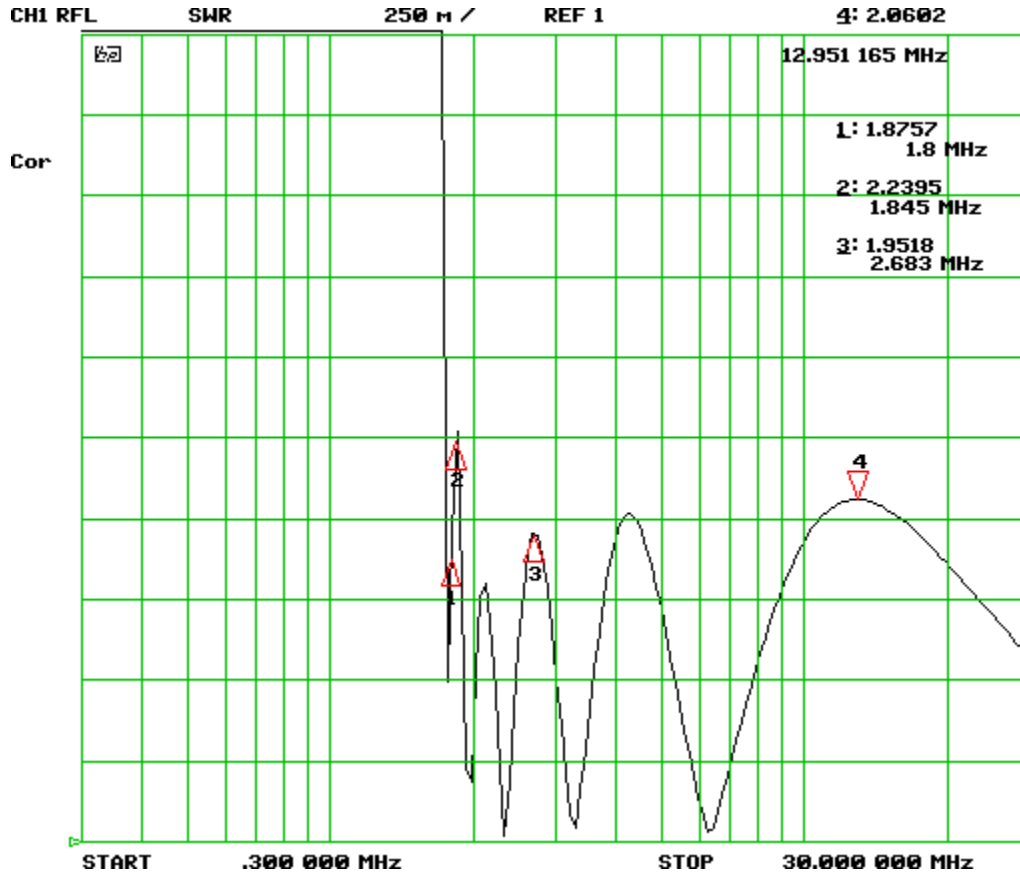

# Schematic

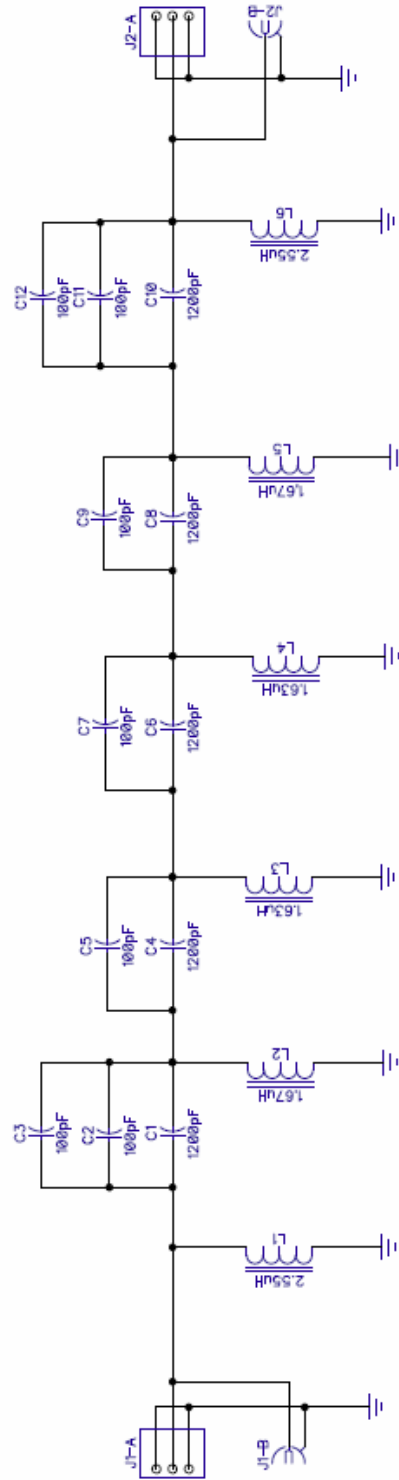

### Notes

All capacitors are 0805 surface mount, 1% tolerance, C0G/NPO ceramic inductors wound on FT50-7 cores and adjusted to 1% tolerance

Two optional connector pads are provided. Normally only one pair will be used.

J1-A and J2-A are 0.1 inch pin header type and may be direct soldered if pin headers are not used.

J1-B and J2-B are for vertical through-hole SMA connectors.