

Elecraft K2 Transceiver SN 5689 Response to Tone Burst in SSB Mode

05 November 2006
Jack R. Smith K8ZOA

www.cliftonlaboratories.com

1. Purpose of Test: Does the reference K2 exhibit RF output overshoot on SSB.
2. Test Setup:

Setup for Elecraft K2 RF Overshoot on SSB

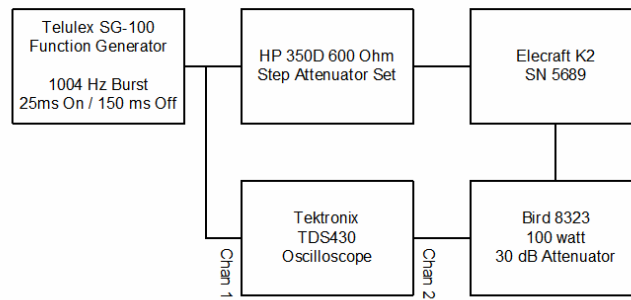

TDS430 run on envelope mode. SG-100 set for 1004 Hz burst mode, 25ms on/150ms off. Step attenuator HP350D adjusted as required for the test condition.

3. K2 settings:
 - a. Microphone strapped for Kenwood compatibility
 - b. SSB A = 1
 - c. SSB C = 1-1
 - d. Power set point 50 watts
 - e. Input Level as show
 - f. TX Freq 7281 KHz, LSB
 - g. TX Commanded to ON via RS-232 port
4. Results:

Note that the audio signal on Chan 1 appears a bit odd due to envelope detection artifacts.

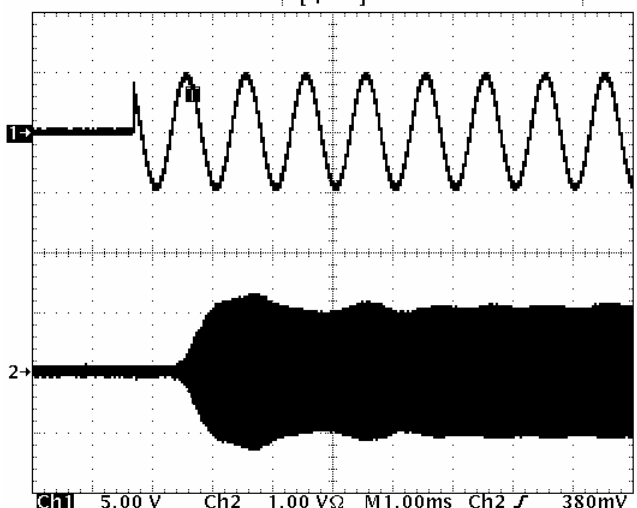
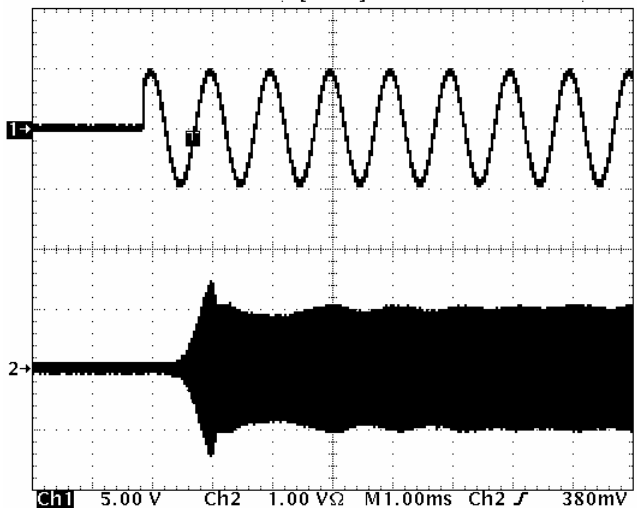
Test Condition & Comments	Oscilloscope
<p>ALC barely flickering. Input level = 0 dB reference</p>	<p>TeK Run: 25.0kS/s Envelope [T]</p>  <p>Ch1 5.00 V Ch2 1.00 VΩ M1.00ms Ch2 380mV 5 Nov 2006 15:30:50</p>
<p>Audio increased +6 dB.</p>	<p>TeK Run: 25.0kS/s Envelope [T]</p>  <p>Ch1 5.00 V Ch2 1.00 VΩ M1.00ms Ch2 380mV 5 Nov 2006 15:32:24</p>

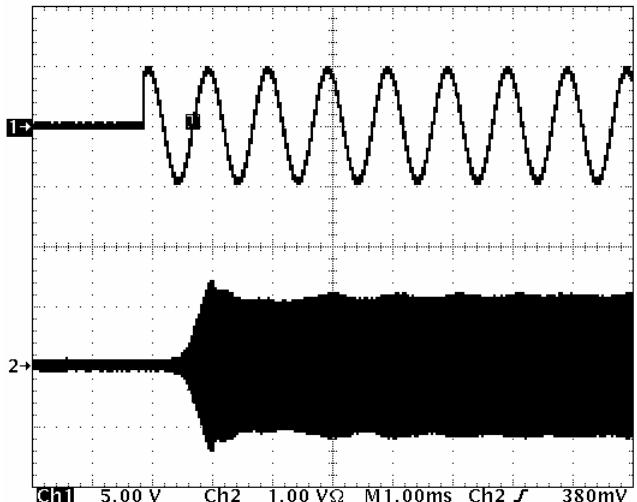
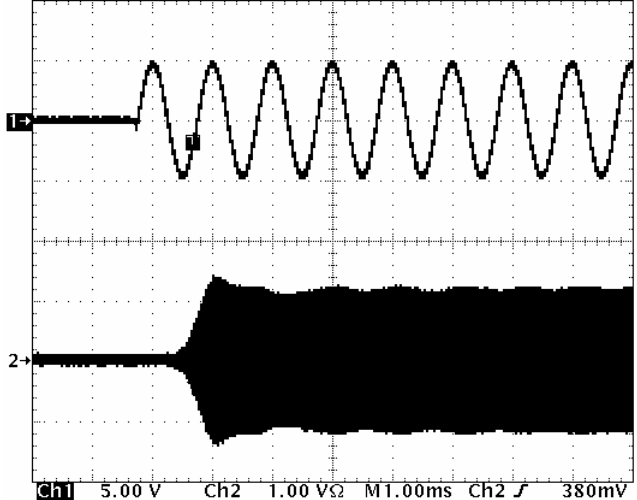
Test Condition & Comments	Oscilloscope
<p>Audio increased +12 dB</p>	<p>TeK Run: 25.0kS/s Envelope [T]</p>  <p>Ch1 5.00 V Ch2 1.00 VΩ M1.00ms Ch2 J 380mV 5 Nov 2006 15:33:26</p>
<p>Audio increased +20 dB ALC shows 3-4 bars illuminated</p>	<p>TeK Run: 25.0kS/s Envelope [T]</p>  <p>Ch1 5.00 V Ch2 1.00 VΩ M1.00ms Ch2 J 380mV 5 Nov 2006 15:34:24</p>

